

DATED

7th June

2023

SUFFOLK COUNTY COUNCIL (1)

- and -

BDW TRADING LIMITED (2)

AGREEMENT

made pursuant to Sections 278 and 38 of the Highways Act 1980  
and any other enabling power relating to  
the development of Land at Quintons Road, East Bergholt, Colchester, CO7 6RB,  
Suffolk

Nigel Inniss  
Head of Legal Services  
Suffolk County Council  
8 Russell Road Ipswich  
Suffolk IP1 2BX

Ref: 72203/AS

**SECTION 278 AGREEMENT  
INDEX**

	Page
<b>Recitals &amp; Definitions</b>	
<b>RECITALS AND DEFINITIONS.....</b>	<b>4</b>
<b>1 LEGAL EFFECT .....</b>	<b>9</b>
<b>2 NOTICES .....</b>	<b>10</b>
<b>3 GENERAL.....</b>	<b>10</b>
<b>4 ARBITRATION .....</b>	<b>11</b>
<b>5 COVENANTS.....</b>	<b>12</b>
<b>1 THE DESIGN OF THE HIGHWAY WORKS .....</b>	<b>16</b>
<b>2 LETTING OF THE CONTRACT.....</b>	<b>17</b>
<b>3 INSPECTION OF THE HIGHWAY WORKS .....</b>	<b>18</b>
<b>4 TESTING OF MATERIALS .....</b>	<b>19</b>
<b>5 OPENING OF THE HIGHWAY WORKS.....</b>	<b>20</b>
<b>6 UNDERTAKERS.....</b>	<b>21</b>
<b>7 PROTECTION OF THE PUBLIC .....</b>	<b>22</b>
<b>10 TIMING.....</b>	<b>24</b>
<b>11 SAFETY .....</b>	<b>24</b>
<b>12 ACCOMMODATION WORKS .....</b>	<b>25</b>
<b>13 CONSTRUCTION (DESIGN AND MANAGEMENT) REGULATIONS 2015 .....</b>	<b>25</b>
<b>14 SITE CLEARANCE AND CERTIFICATE(S) OF SUBSTANTIAL COMPLETION .....</b>	<b>27</b>
<b>15 DEFECTS CORRECTION PERIOD AND CERTIFICATE OF FINAL COMPLETION .....</b>	<b>27</b>

16 INDEMNITY .....29

17 PERFORMANCE BOND / ~~PERFORMANCE Cash deposit~~ .....30

18 COMMUTED SUMS FOR MAINTENANCE .....31

19 LEGAL AND ADMINISTRATIVE COSTS.....31

20 PARTS I AND II OF THE LAND COMPENSATION ACT 1973 .....33

SCHEDULE II.A.....35

SCHEDULE III .....39

SCHEDULE IV.....40

*MB*

THIS AGREEMENT is made the 7<sup>th</sup> day of JUNE 2023  
BETWEEN the following parties :-

- (1) **SUFFOLK COUNTY COUNCIL** of Endeavour House 8 Russell Road Ipswich Suffolk IP1 2BX ("the County Council")
- (2) **BDW TRADING LIMITED** (company number 03018173) of Barratt House, Cartwright Way, Forest Business Park, Bardon Hill, Coalville, Leicestershire, LE67 1UF ("the Developer")

RECITALS AND DEFINITIONS

(A) In this Agreement unless the context otherwise requires the following words shall have the following meanings :-

"1980 Act"	Means the Highways Act 1980 (as amended)
"Approved Contractor"	Means the contractor(s) approved by the County Council for carrying out the Highway Works of the value and complexity proposed
"Approved Sub-Contractor"	Means the sub-contractor(s) approved by the County Council for carrying out the Highway Works of the value and complexity proposed
"CDM Regulations"	Means the Construction (Design and Management) Regulations 2015 (SI 2015/51)
"Certificate of Final Completion"	Means any of the certificates referred to in paragraph 15.3 of Schedule I
"Certificate of Substantial Completion"	Means any of the certificates referred to in paragraph 14.2 of Schedule I
"Committed Sums"	Means the sum of £6,118.50 (six thousand, one hundred and eighteen pounds and fifty pence) which is calculated, as set out in paragraph 18.1 on Schedule I towards the cost of the County Council's future maintenance liability of the Highway Works]

"Compensation Figure"	Means the sum of £29,650.00 (twenty-nine thousand and six hundred and fifty pounds) which is the amount which the Director reasonably considers sufficient to meet the likely cost of settling claims and connected costs under Part I of the Land Compensation Act 1973
"Compensation Cash Deposit"	Means the cash deposit to be paid to the County Council in the sum of the Compensation Figure being the sum the County Council reasonably considers sufficient to meet the likely cost of settling claims and connected costs under Part I of the Land Compensation Act 1973
"Contract"	Means the contract or contracts in respect of each and all of the Highway Works
"Contractor"	Means the contractor or contractors who have been awarded the Contract to execute the Highway Works. For the avoidance of doubt the aforementioned definition does not include any subcontractor
"Development"	Means the development to be carried out pursuant to the Permission
"Director"	Means the County Council's Executive Director of Growth, Highways and Infrastructure or other officers of the County Council acting under his hand
"Highways England"	Means the body appointed by the Secretary of State for Transport as a strategic highways company under section 1 of the Infrastructure Act 2015 and statutory instrument 2015/376 or any other body so appointed
"Highway Works"	Means the works collectively or individually as the context requires which are set out in Schedule III of this Agreement and shown in the Works Drawings
"Highway Structure"	Means any bridge, subway, culvert, pipe, tunnel, or other structure built in, over, under or adjacent to any part of the highway

“Performance Bond”	Means the bond with the Performance Bond Surety for each and all of the Highway Works, such bond to be in the form set out in Schedule II.A, to the effect that should the Developer default in the execution of its obligations to carry out the Highway Works and to maintain the same in accordance with the provisions of this Agreement then the County Council will call upon the Performance Bond Surety to provide the full value of the Performance Bond (subject to the provisions hereinafter contained) to carry out the Highway Works and maintain the same as aforesaid
“Performance Figure”	Means the sum of £462,000.00 (four hundred and sixty-two thousand pounds) being the Tender Sum plus 10 per cent in respect of the Highway Works and as set out in each of the Contracts
“Performance Bond Surety”	Means National House-Building Council
“Permission”	Means the planning permission granted by Babergh District Council dated 23 <sup>rd</sup> November 2017 granted with reference number B/15/00673 in respect of the Site together with any modification of it
“Road Safety Audit”	Means the evaluation of each and all of the Highway Works during design and at the end of construction to identify potential road safety problems that may affect any users of the highway and to suggest measures to eliminate or mitigate those problems in accordance with Department for Transport standards or by the County Council as agreed by the Director
“Site”	Means Land at Quintons Road, East Bergholt, Colchester, CO7 6RB, Suffolk shown edged red for identification only on the attached plans numbered H8771-3B-GA-220 T2 and H8771-3B-GA-221 T3 and H8771-3B-GA-222 T2 currently registered under title number SK414843
“Specification”	The County Council’s “Specification for Estate Roads” dated May 2007 (or later amendment current at the date of this

Agreement) so far as this is consistent with the Works Drawings and description in Schedule III (subject to any variations agreed in writing by the Director)

“Sub-contractor” Means the sub-contractor(s) working for the Contractor(s) who have been contracted to execute the Highway Works

“Substantial Completion” Means complete to the reasonable satisfaction of the Director and so that the Highway Works can be used for the purpose and operate in the manner for which they were designed

“Technical Standards” Means the standards necessary to ensure complete conformity with all UK primary and secondary legislation (including by-laws) all guidance standards and codes of practice issued by the Department for Transport the County Council statutory undertakers and relevant professional institutes the Road Safety Audit and formal instructions issued by the Director from time to time during the design and implementation of the Highway Works and for the avoidance of doubt this shall include the Traffic Signs Regulations and General Directions 2016 and BS5489 in relation to the design of any street lighting

“Tender Sum” Means the sum of £420,000 (four hundred and twenty thousand pounds) (including the costs associated with statutory undertakers work and traffic management) agreed by the Director for carrying out the Contract by the Contractor

“Works Drawings” Means the attached drawings bearing the numbers referred to in Schedule IV or any subsequent revision of them which has been approved or requested by the Director and which relate to the Highway Works

(B) In this Agreement unless the context otherwise requires :-

- (i) Words importing the singular meaning where the context so admits include the plural meaning and vice versa; and
- (ii) Words of the masculine gender include the feminine and neuter genders and words denoting actual persons include companies, corporations and firms and all such words shall be construed interchangeably in that manner; and

- (iii) "party" or "parties" means a party or parties to this Agreement; and
  - (iv) references to any party shall include the successors in title and assigns of that party; and in the case of the County Council the successors to its statutory functions; and
  - (v) where a party includes more than one person any obligations of that party can be enforced against all of them jointly and severally unless there is an express provision otherwise; and
  - (vi) the headings and contents list in this Agreement shall not form part of or affect its construction; and
  - (vii) references to clauses schedules and paragraphs are references to clauses in and schedules to this Agreement and paragraphs in schedules to this Agreement; and
  - (viii) where a party or any officer or employee is required to give its consent approval or agreement to any specific provision in this Agreement such consent approval or agreement shall not be unreasonably withheld or delayed; and
  - (ix) any mention herein of any act or of any section regulation or statutory instrument shall be deemed to refer to the same source as at any time amended and where such act section regulation or statutory instrument has been replaced consolidated or re-enacted with or without amendment such mention shall be deemed to refer to the relevant provision of the updating consolidating or re-enacting act or section or regulation or statutory instrument
- (C) The County Council is the highway authority (except for trunk roads) for the purposes of the 1980 Act for the area within which the Site is situated and the Highway Works will be carried out
- (D) The Developer has the benefit of the Permission
- (E) The Developer is the registered proprietor with title absolute of the Site in so far as it is registered at the Land Registry under Title Number SK41483



(F) The Developer wishes to dedicate as public highway that part of the Site upon which the Highway Works are to be constructed which do not currently form part of the public highway and the County Council agrees to accept such dedication and adopt that part of the Site and the Highway Works as highway maintainable at public expense on the terms and conditions hereinafter contained

(G) Having regard to the development plan and other material considerations the County Council considers it expedient in the interests of the proper planning of their area that the Highway Works need to be carried out to facilitate the Development and that entering into this Agreement will be of benefit to the public

NOW THIS DEED WITNESSES as follows:-

1 LEGAL EFFECT

1.1. This Agreement and the covenants that appear hereinafter are made pursuant to Sections 38 72 and 278 of the 1980 Act Section 111 of the Local Government Act 1972 and Section 1 of the Localism Act 2011 and all other enabling powers to the intent that the provisions of this Agreement shall bind the Site and the parties hereto and all persons deriving title through or under them

1.2. This Agreement is a Deed. Any financial default under this Agreement will be registered as a Local Land Charge under section 278(5)(c) of the 1980 Act

1.3. No waiver (whether express or implied) by the County Council of any breach or default by the Developer in the performance or observance of any of the covenants, terms or obligations in this Agreement shall constitute a continuing waiver and no such waiver shall prevent the County Council from enforcing any of the covenants, terms or obligations or from acting upon any subsequent breach or default in respect thereof

1.4. Any provision of this Agreement which is or may be unlawful void or unenforceable shall to the extent of such unlawfulness invalidity or unenforceability be deemed severable and shall not affect any other provision of this Agreement

1.5. This Agreement is governed by and interpreted in accordance with English law and shall be determined in the Courts of England

2 NOTICES

2.1. Any notices or other written communication to be served or given by one party upon or to any other party under the terms of this Agreement shall be deemed to have been validly served or given if delivered by hand or sent by recorded delivery post or sent by the DX service to the party upon whom it is to be served or to whom it is to be given or as otherwise notified for the purpose by notice in writing provided that the notice or other written communication is addressed and delivered by hand or by recorded delivery post or by the DX service to the address of the party concerned as nominated in sub-clause 2.2. below

2.2. The address for any notice or other written communication in the case of each party to this Agreement shall be as follows:-

The County Council      Suffolk County Council Endeavour House 8 Russell Road Ipswich IP1 2BX marked for the attention of the Assistant Director of Governance, Legal and Assurance (or where the context requires the Executive Director of Growth, Highways and Infrastructure, Endeavour House 8 Russell Road Ipswich IP1 2BX)

The Developer      marked for the attention of the Managing Director

2.3. Any notice or other written communication to be given by the County Council shall be deemed to be valid and effective if on its face it is signed on behalf of the County Council by a duly authorised officer

*myk*  
*7*  
*TOM B WRIGHT OF BDW*  
*Eastern Counties Approach, Chelmsford Essex, CM2 5EY*  
*7 Springfield Lyons*

3 GENERAL

3.1. All works and activities to be carried out under the terms of this Agreement (including for the avoidance of doubt such works as are of a preparatory ancillary or of a maintenance nature) are (save where

expressly provided otherwise) to be at the sole expense of the Developer and at no cost to the County Council

- 3.2. All consideration given and payments made in accordance with the provisions of this Agreement shall be exclusive of any VAT properly payable in respect thereof and in the event of VAT becoming chargeable at any time in respect of any supply made in accordance with the terms of this Agreement then to the extent that VAT had not previously been charged in respect of that supply the person making the supply shall raise a VAT invoice to the person to whom the supply was made and the VAT shall be paid accordingly
- 3.3. The County Council and their respectively duly authorised officers and agents may enter upon the land on which the Highway Works are being carried out at any reasonable time to ascertain whether the terms of the Agreement are being or have been complied with

#### 4 ARBITRATION

- 4.1. Any dispute or difference arising between the parties as a result of this Agreement may be referred to the arbitration of a single arbitrator to be agreed upon between the parties or failing agreement within fourteen days after either of the parties has given to the other a written request requiring the appointment of an arbitrator to a person to be appointed at the request of either of the parties by the President for the time being of The Institution of Civil Engineers
- 4.2. Any reference to arbitration shall be undertaken in accordance with and subject to the provisions of the Arbitration Act 1996 save as follows:-
  - (a) the seat of the arbitration shall be at the County Council's offices in Ipswich Suffolk
  - (b) where appropriate the arbitrator may consolidate arbitral proceedings
  - (c) with the parties' agreement the arbitrator may appoint experts or legal advisers

4.3 A party wishing to refer any such dispute or difference to arbitration shall notify the other party in writing of such intention without delay

4.4 The arbitrator shall act as a referee and not as an expert except in any case where the parties to a dispute or difference agree on the arbitrator when such parties may also agree that such arbitrator shall act as an expert

4.5 Subject to Sections 67 68 and 69 of the Arbitration Act 1996 the parties agree to be bound by the decision of the arbitrator

## 5 COVENANTS

5.1 The Developer covenants and warrants to the County Council that they have full power to enter into this Agreement and there is no other person having a charge over or any other interest in the Site whose consent is necessary for the Developer to enter into this Agreement and to comply with the obligations set out at paragraph 14.3 of Schedule I

5.2 The Developer hereby covenants and undertakes with the County Council that from the date of this Agreement it will (unless otherwise agreed by the County Council) carry out and comply with the obligations set out in Schedule I and the details set out in Schedules III and IV hereto

5.3 The County Council without prejudice to its statutory powers and duties hereby appoints the Developer to act as its agent and gives to the Developer licence (in so far as is reasonably necessary for the Developer to perform the obligations under the terms of this Agreement) to enter into and upon and remain upon the highway to carry out the construction of the Highway Works within the timescales referred to in Schedule III hereto or such other period as may be agreed in writing by the Director, provided that this licence shall not extend to the Developer's successors in title or assigns unless otherwise agreed in writing by the Director prior to that successor or assignee commencing work in the public highway

5.4 The Developer covenants with the County Council not to commence the Highway Works set out in Schedule III unless road space has first been booked with the County Council

5.5 The Developer covenants with the County Council as highway authority to give written notice not less than three calendar months prior to works commencing, in order that the County Council as highway authority has sufficient time to ensure that the commencement of works will cause the least disruption possible to road users and the County Council reserves the right to refuse consent and/or to stop or require the stopping of works under the terms of this Agreement and relevant legislation where the aforesaid notice period is not complied with

5.6 The Developer covenants with the County Council as highways authority to comply with the provisions of the New Roads and Street Works Act 1991, the Traffic Management Act 2004 and any amendments thereof

5.7 The County Council covenants with the Developer that on the date of issue of the Certificate of Final Completion the roads subject to the Highway Works shall thenceforth be, to the extent they are not already, adopted as highways maintainable at the public expense

## 6 THIRD PARTY RIGHTS

6.1 It is hereby agreed and declared that the provisions of Contracts (Rights of Third Parties) Act 1999 shall not apply to this Agreement

## 7 LAPSE

7.1 If the Highway Works have not been commenced within one (1) year from the date of this Agreement, save as this period is otherwise extended in writing by the Director at his discretion, then this Agreement shall lapse and be of no further effect (save to the extent already complied with) and the Developer agrees to pay to the County Council any costs properly incurred by the County Council prior to the lapse of this Agreement (which have not already been paid) including but not limited to those costs set out in paragraph 19 of Schedule I to this Agreement

7.2 Where, in accordance with clause 7.1 above the Director, at his discretion, agrees in writing to an extension to the period of one (1) year after which this Agreement shall lapse, this Agreement shall lapse at the end of such period as agreed in writing by the Director where the Highway Works have not been commenced by the expiry of that extension period

In witness whereof this Agreement has been executed and delivered as a Deed on  
the date first written above

The COMMON SEAL of )  
SUFFOLK COUNTY COUNCIL )  
was hereunto affixed )  
in the presence of )



  
.....  
A Duly Authorised Officer

**SIGNED as a DEED by**

**Brandon Schmidt**  
.....  
(Print name of Attorney)  
as Attorney for  
**BDW TRADING LIMITED**  
in the presence of:

  
.....  
(Sign here)

Witness Signature:  .....

Name (in full): **Stewart Smith** .....

Address c/o 7 Springfield Lyons Approach, Chelmsford, Essex CM2 5EY

and

**Dan Griffin**

.....  
(Print name of Attorney)  
as Attorney for  
**BDW TRADING LIMITED**  
in the presence of:

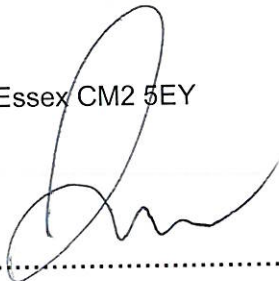
  
.....  
(Sign here)

Witness Signature:  .....

Name (in full): **Stewart Smith** .....

Address c/o 7 Springfield Lyons Approach, Chelmsford, Essex CM2 5EY

## SCHEDULE I

### 1 THE DESIGN OF THE HIGHWAY WORKS

1.1 The design of the Highway Works shall be to the satisfaction of the Director with due consideration of the Technical Standards

1.2 No work on any of the Highway Works shall commence and no Contract for their construction shall be let until

1.2.1 full details of the design of the Highway Works to be commenced in the form of plans, drawings, specifications and other materials have been submitted to the Director together with the name of the principal designer (whom the Developer shall appoint for the full duration of the design and construction of each and all of the Highway Works) in accordance with the CDM Regulations and any codes of practice referred to therein

1.2.2 the Director has given his written approval to the Highway Works to be commenced and such approval shall not be given if the said plans, drawings, specifications and other documentation have not adequately addressed the issues raised in the pre-construction stages of the Road Safety Audit process and if given shall lapse if the Highway Works are not commenced within twelve (12) months of the date of the said Director's approval

1.2.3 preliminary proposals, detailed contract drawings, schedules and specifications for Highway Structures have been prepared by the Developer and submitted for written approval to the Director's Bridge Office in accordance with Department for Transport Document BD2/12 and the structural design and checking procedure has been carried out by an incorporated or chartered engineer familiar with Department for Transport Codes of Practice and experienced in the design of Highways Structures. The documents are to be agreed as applicable with the Director before the design is commenced and details are submitted for approval



1.3 If the Director does not propose to give his approval in relation to those matters referred to in paragraph 1.2 of this Schedule he shall in each case as soon as possible in writing inform the Developer and if the Director requires amendments or additions to the plans drawings specifications and other materials referred to in paragraph 1.2 of this Schedule these amendments shall be undertaken by the Developer at his own expense and a revised set of updated documents shall be re-submitted to the Director for his approval

1.4 Without prejudice to paragraph 1.2 of this Schedule, the Director shall not give his approval as referred therein until the Developer has paid the sum referred to in paragraph 19.1.3 towards the cost of checking the design of the Highway Works and inspecting the Highway Works. The Highway Works always shall be carried out in accordance with the plans, drawings, specifications and other materials which have received the Director's approval referred to in paragraph 1.2 of this Schedule and the Developer shall in the execution of the Highway Works comply or ensure that the Contractor complies with the Technical Standards

## 2 LETTING OF THE CONTRACT

2.1 No Contract shall be let until all traffic management measures have been prepared by the Developer and approved in writing by the Director ("the approved programme") and thereafter each of the Contracts will be offered to an Approved Contractor

2.2 The Contract to be let under paragraph 2.1 of this Schedule shall be let under NEC3 suite of contracts (and any amendments thereto shall be approved by the Director) and the Developer shall obtain the agreement of the Contractor to be bound by the agreed drawings in Schedule IV

2.3 The Contract shall be awarded by the Developer subject to the Director having first given his written approval to the proposed chartered engineer(s) or other suitably qualified person(s) who shall be independent of the Contractor and will supervise the execution of the Highway Works by the Contractor

2.4 The Developer shall not award the Contract unless the Approved Contractor and the Approved Sub-Contractor/s concerned are insured throughout the period of the Contract (such period to include the

maintenance period detailed in paragraph 15.1 of this Schedule) for public liability risks in the sum of at least ten million pounds (£10,000,000) in respect of any single claim and the Developer shall ensure that the Contractor remains so insured throughout the period of the Contract and prior to the commencement of each or all of the Highway Works or any maintenance works carried out in accordance with paragraph 15.1 of this Schedule the Developer shall produce to the Director insurance policies fully covering the Developer's liability in respect of the matters set out in this Agreement

- 2.5 The Developer shall not sub-contract or assign the Contract without the written approval of the Director and any sub-contractor shall be an Approved Sub-Contractor

### 3 INSPECTION OF THE HIGHWAY WORKS

- 3.1 The Developer shall provide the Director with not less than twenty-four (24) hours nor more than seventy-two (72) hours' notice (excluding weekends and bank holidays) of any intended execution of the Highway Works specifying the tasks to be carried out in accordance with the approved programme referred to in paragraph 2.1 of this Schedule
- 3.2 Without prejudice to the approved programme the Developer shall notify the Director in writing at least twenty-eight (28) days prior to the commencement of any work connected with statutory undertaker's equipment
- 3.3 Without prejudice to the approved programme the Developer shall notify the Bridge Office and the Director in writing at least seventy-two (72) hours prior to the commencement of each and every stage of excavation and concrete operations associated with any Highway Structures
- 3.4 The Developer shall during the progress of each and all of the Highway Works give to or procure for the Director and any person or persons duly authorised by him free access to every part of the Highway Works and the Site and permit him or them to inspect the same as they proceed and all materials used or intended to be used therein and shall give effect to any reasonable and proper requirements made or reasonable and proper directions given by the Director to conform to the approved detailed plans

Works Drawings and specification referred to in paragraph 1.2 of this Schedule

- 3.5 The Developer shall not cover up or put out of view any works forming part of the Highway Works without the approval of the Director and shall afford full opportunity for the Director to examine and measure any work which is about to be covered up or put out of view and to examine foundations before permanent work is placed thereon and shall give at least seventy-two (72) hours' notice to the Director whenever any such work or foundations is or are ready or about to be ready for examination
- 3.6 The Director shall without unreasonable delay, unless she considers it unnecessary and advises the Developer accordingly, attend when required by the Developer for the purpose of examining such works or of examining such foundations
- 3.7 The Director shall for the purposes of paragraphs 3.1 to 3.6 be allowed reasonable access and admission to the Highway Works or the places where materials or plant for the Highway Works may be stored or in the course of preparation manufacture or use (unless such access or admission is refused due to circumstances beyond the control of the Developer)

#### 4 TESTING OF MATERIALS

- 4.1 The Developer shall reimburse the County Council for all reasonable costs and expenses whatsoever arising from the operation of paragraphs 4.2 to 4.5
- 4.2 The Director shall require the testing of materials plant and workmanship used or proposed to be used in the Highway Works and in his reasonable discretion have the power to reject any materials plant or workmanship so tested which he may reasonably and properly find to be not in accordance with the approved detailed plans Works Drawings and specification referred to in paragraph 1.2 of this Schedule In relation to Highways Structures the Director will require a schedule of testing to be agreed prior to the commencement of works or any part thereof
- 4.3 The Developer shall as soon as is reasonably practicable replace or repair any materials plant or workmanship which have been found to be

not in accordance with the approved detailed plans Works Drawings and specification referred to in paragraph 1.2 of this Schedule

4.4 The Director shall for the purposes of paragraphs 4.2 to 4.5 be allowed reasonable access and admission to the Highway Works or the places where materials or plant for the Highway Works may be stored or in the course of preparation manufacture or use (unless such access or admission is refused due to circumstances beyond the control of the Developer)

4.5 The Developer shall as soon as is reasonably practicable remove such materials and plant as are rejected by the Director pursuant to paragraph 4.2. of this Schedule which are not capable of repair or remedy from the Site and if the Developer shall wish to continue to store such rejected materials and plant on the Site they shall be stored separately from those materials and plant which have not been so rejected or which the Developer shall wish in future to use in execution of the Highway Works

## 5 OPENING OF THE HIGHWAY WORKS

5.1 During the construction of each and all of the Highway Works and prior to the issue of the Certificate of Substantial Completion:

- (a) the Director may issue instructions to the Developer to open or expose any of the Highway Works which has been covered up without previously being inspected by the Director
- (b) should the Developer fail to comply with any such instructions the County Council may so take up or expose the relevant part of the Highway Works causing as little damage or inconvenience as is possible in respect of any other part or parts of the Highway Works the reasonable and proper cost of such taking up or exposure and reinstatement to be met by the Developer

PROVIDED THAT if the Highway Works or any part or parts thereof are covered up by the Developer after giving the notice referred to in paragraph 3.5 of this Schedule and the Director shall have failed to inspect in the period therein referred to and the Director shall subsequently require the Highway Works or any part of them to be uncovered for the purposes of inspection:-

- (a) if inspection reveals the relevant part or parts of the Highway Works to have been completed in accordance with the approved detailed plans drawings and specification referred to in paragraph 1.2 of this Schedule all costs in respect of such uncovering and inspection and of reinstating the part or parts of the Highway Works uncovered shall be borne by the County Council; or
- (b) if inspection reveals the relevant part or parts of the Highway Works not to have been completed in accordance with the approved detailed plans drawings and specifications referred to in paragraph 1.2 of this Schedule all reasonable and proper costs in respect of uncovering and inspection and of reinstating the part or parts of the Highway Works uncovered shall be borne by the Developer

## 6 UNDERTAKERS

6.1 Insofar as the County Council as Highway Authority is required by any legislation regulation direction or code of practice (including in particular but without prejudice to the generality of the foregoing the New Roads and Street Works Act 1991) to serve a notice or notices in respect of the Highway Works on undertakers or other persons the Developer shall comply with such requirement on behalf of the County Council before the Highway Works commence and shall thereafter assume on behalf of the County Council such responsibilities as follow on therefrom in particular during the construction of the Highway Works and prior to the issue of the Certificate of Substantial Completion the Developer shall also:-

- (a) carry out or procure the carrying out of such works and activities in regard to the plant and equipment of undertakers as are required by undertakers in accordance with their statutory powers under the New Roads and Street Works Act 1991 as a result of the construction or intended construction of each and all of the Highway Works
- (b) cause all public sewers, highway drains gas and water mains electric cables and telecommunications ducts or other apparatus which are to be laid by the Developer under the Highway Works together with all necessary connections from them to the boundary of the Highway Works to be laid so far as is practicable under the

Highway Works before the foundation of the Highway Works are laid and shall also in so far as is practicable cause the connections from electric cables to any street lamp to be laid before the paving of the footways comprised in the Highway Works is carried out

- (c) cause all trench works within the highway to be backfilled and reinstated in accordance with the Specification for the Reinstatement of Openings in the Highway as determined from time to time under the New Roads and Street Works Act 1991
- (d) not at any time give consent to the erection by any telecommunications operator of telegraph poles or telephone poles or to the erection by any statutory undertaker or public or private company firm or individual of any over ground or underground equipment without the consent in writing of the Director

## 7 PROTECTION OF THE PUBLIC

- 7.1 The Developer shall give due consideration to adjoining owners and occupiers at all times and shall organise activities relating to the Highway Works in such a manner as to cause the least practicable disruption
- 7.2 Prominent notices shall be displayed and maintained around the perimeter of the site of each and all of the Highway Works to warn the public of the dangers of entering the Site
- 7.3 The Developer shall nominate a member of the site management team as the contact point for the Director in the event of an emergency and shall advise a daytime and twenty-four (24) hour contact number to the Director for the same purpose
- 7.4 The Developer shall take or procure the taking of all necessary steps to avoid creating a nuisance from noise and in particular:
  - 7.4.1 the Developer shall afford all reasonable facilities to enable the Director to carry out such site investigations as she may deem necessary in order to determine noise emission levels
  - 7.4.2 all vehicles and plant including compressors shall be fitted with effective silencers and acoustic covers as appropriate and maintained in good working order and all static plant shall be

located to minimise nuisance to persons living or working in the vicinity

7.4.3 all portable traffic signals and pumps shall be operated from mains electricity unless otherwise agreed with the Director

7.4.4 noisy activities shall not be permitted on Sundays and Bank Holidays and except as agreed in writing by the Director shall not be permitted outside the hours of 9.30 a.m. to 4.30 p.m. Monday to Friday and 9.30 a.m. to 1 p.m. on Saturdays

PROVIDED THAT if in the reasonable opinion of the Director the Developer is not dealing adequately with the control of noise the Developer shall carry out or procure the carrying out of such additional measures as the Director considers necessary at the Developer's expense

7.5 Compliance with the provisions of paragraph 7.4 shall not relieve the Developer of any of his obligations and liabilities under this Agreement the Control of Pollution Act 1974 or the Environmental Protection Act 1990

7.6 The Developer shall take or procure the taking of all necessary steps to avoid creating a nuisance from dust and as far as practicable works are to be carried out in such a way that dust is kept to a minimum PROVIDED THAT if in the reasonable opinion of the Director the Developer is not dealing adequately with the control of dust the Developer shall carry out or procure the carrying out of such additional measures as the Director considers necessary at the Developer's expense

7.7 The Developer shall arrange the regular removal of refuse likely to encourage vermin and arrange for suitable secure storage containers to be provided for collection

7.8 The Developer shall keep a log book on site to record all complaints received from the public and the action taken in response and the log book shall be available for inspection by the Director

8 PREVENTION OF MUD BEING CARRIED ON THE PUBLIC HIGHWAY

- 8.1 Provision shall be made at the Site to limit in so far as is practicable the amount of mud dust and other materials carried on to adjacent public highways by vehicles and plant leaving the Site
- 8.2 The Developer shall keep or procure the keeping of all roads footpaths rights of way and other means of passage leading to or from or crossing the Site free from mud slurry or other hazardous substances that are deposited through the construction of the Highway Works and any such substance so deposited on any such road footpath right of way or other means of passage shall be promptly removed by or at the direction of the Developer
- 8.3 The Director may close any associated crossings entrances and exits if such substances deposited are not promptly removed by the Developer and any losses or expenses incurred as a result shall be borne by the Developer and on removal of such substances the Director shall reopen such crossings entrances and exits and the Developer shall bear the costs incurred

9 TRAFFIC CONTROL

- 9.1 During the periods when the Highway Works are being executed the Developer shall institute at his own expense measures previously approved in writing by the Director to maintain the safe flow of traffic on the highways in the vicinity of the site of the Highway Works
- 9.2 The Highway Works shall be signed and protected to at least the standards of Chapter 8 of the Traffic Signs Manual published by His Majesty's Stationery Office and the proposed arrangements shall be approved in writing by the Director before the Highway Works commence

10 TIMING

- 10.1 No Highway Works within or affecting existing public highways or temporary diversions which could interfere with the traffic flow will be permitted within the morning and evening peak periods i.e. 7.30 - 9.30 a.m. and 4.30 - 6.30 p.m. Monday to Friday except as agreed in writing by the Director

11 SAFETY



- 13.4.1 a plan showing the land over which those Highways Works have been constructed and
  - 13.4.2 a Health and Safety file conforming in all respects with the CDM Regulations and which shall accord with the current format used by the County Council to include a separate Health and Safety File for each Highway Structure
- 13.5 The Director shall be at liberty to delay issue of the Certificate of Final Completion in respect of any of the Highway Works if the Developer fails to provide the Director with the documents referred to in 13.4.1 and 13.4.2 above within twenty-eight (28) days of issue of any Certificate of Substantial Completion for any of the Highway Works equivalent to the number of days after the twenty-eight (28) day period that the documents were submitted
- 13.6 In respect of the Highway Works generally the Developer shall provide to the Director the final information in both paper and electronic format and shall at least comprise:
- 13.6.1 1:500 scale (or alternative scale as may be specified by the Director) "as built" drawings
  - 13.6.2 records of the earthworks showing sources of material used in areas of fill description of fill materials descriptions of sub-grades in cut areas copies of results of tests of material carried out as part of the supervision of the construction of the earthworks
  - 13.6.3 records of the sources of supply of all deliveries of road construction materials with details of the location of the Highway Works at which each load is placed
  - 13.6.4 records of the sources of supply of all other manufactured materials (e.g. drainage goods, fencing materials, traffic signs, electrical components and cables etc).
- 13.7 No work on Highway Structures shall commence until the general Health and Safety file information including format to be supplied in respect of Highway Structures has been agreed with the County Council's Bridge Engineer and shall accord with the County Council's current Technical

Approval Procedure for Highway Structures

13.8 The Developer shall indemnify and keep the County Council indemnified against any breach of the Developer's obligations under this paragraph 13

14 SITE CLEARANCE AND CERTIFICATE(S) OF SUBSTANTIAL COMPLETION

14.1 On Substantial Completion of the Highway Works the Developer shall:-

14.1.1 clear away and remove from the site of the Highway Works all constructional plant and temporary works of every kind and leave the site of the Highway Works in a neat and tidy condition to the satisfaction of the Director and

14.1.2 carry out stage 3 of the Road Safety Audit process and comply to the satisfaction of the Director with recommendations arising thereunder prior to the opening of the Highway Works to the public

14.2. Upon Substantial Completion of the Highway Works including any additional work resulting from stage 3 of the Road Safety Audit process to the satisfaction in all respects of the Director he shall issue a Certificate of Substantial Completion in respect of those Highway Works to the Developer provided that all costs and expenses owing to the County Council have been paid in respect of those Highway Works

14.3. The Developer hereby agrees that on the date of Substantial Completion that part of the Site upon which the Highways Works are constructed which does not currently form part of the public highway shall be dedicated as highway under section 38 of the 1980 Act

14.4. After the issue of the Certificate of Substantial Completion the County Council may approve a reduction of up to 90% of the Performance Figure in respect of the relevant Highway Works and the County Council may release the Developer and the Performance Bond Surety and each of them from their obligations under the Performance Bond in respect of the relevant Highway Works to such extent

15 DEFECTS CORRECTION PERIOD AND CERTIFICATE OF FINAL COMPLETION

The Developer shall maintain each and all of the Highway Works for a period of eighteen (18) months (unless the Director agrees in writing a lesser period having considered paragraph 15.2) from the issue of the related Certificate of Substantial Completion and prior to the expiration of this period the Developer shall reinstate and make good any damage or defect which may have arisen from any cause whatsoever or be discovered during the said period of eighteen months (including any defect in or damage to the surface water drainage system) so as to place the highway and the Highway Works in a condition satisfactory to the Director

After the expiration of the period of twelve (12) months from Substantial Completion or the date the Development becomes operational (whichever is the latter) the Developer shall (unless the Director writes to the Developer informing him that it is to be carried out sooner or that he does not need to do so) carry out stage 4 of the Safety Audit and comply to the satisfaction of the Director with any recommendations arising thereunder

After the expiration of the period of eighteen (18) months referred to in paragraph 15.1 (or such lesser period as agreed in writing by the Director under paragraph 15.1) and after any defects have been made good as therein provided including any improvements arising under stage 4 of the Road Safety Audit to the satisfaction of the Director and after the provisions of paragraph 13.4 and paragraph 20.5 of this Schedule have been fulfilled the Director shall issue forthwith to the Developer the Certificate of Final Completion in respect of the Highway Works provided that the Certificate of Final Completion shall in the case of road gullies extend only as far as their points of entry to the surface water sewers where those are not being adopted by the County Council as highway drains and upon the issue of the Certificate of Final Completion the County Council shall release the Developer and the Performance Bond Surety and each of them from all subsisting obligations under the Performance Bond in respect of those Highway Works

If called upon to do so by notice in writing served within twenty-one years of the date hereof by the County Council the Developer agrees to transfer to the County Council in consideration of one pound any land over which

any part of the Highway Works have been constructed which does not at the date of this Agreement already form part of the highway together with any other land dedicated as public highway by the Developer hereunder free in each case from encumbrances and together with all rights necessary to permit the use inspection maintenance repair and replacement of all utility systems servicing the Highway Works and not vested in the relevant undertaker as are situated outside the limits of the Highway Works and the said other land

16 INDEMNITY

16.1 The Developer shall from the date of this Agreement indemnify the County Council against all claims charges costs expenses liability or loss whatsoever arising out of and incidental to any or all of the Highway Works including but not limited to those arising out of any legally sustainable claims for payments under Section 10 of the Compulsory Purchase Act 1965 and Part I of the Land Compensation Act 1973 (as amended) in connection with those Highway Works provided that the Developer's indemnity will not extend to any claims submitted to the County Council arising out of the negligence of the County Council's employees or arising out of any works of alteration carried out to any of the Highway Works by the County Council after the issue of the related Certificate of Final Completion

16.2 The County Council shall notify the Developer forthwith upon receipt of any such claim or liability

16.3 The County Council shall not accept or settle any claim without first having given the Developer the opportunity to provide the County Council with representations as to the validity of such claim

16.4 The indemnification referred to in paragraph 16.1 includes:

16.4.1 all fees incurred by claimants which the County Council is obliged to pay, and those of the County Council or its agent or contractor, in negotiating any claims (together with VAT payable on the claimants' professional advisors' fees);

16.4.2 statutory interest payments to claimants and their professional advisors; and

16.4.3 the County Council's reasonable and proper legal costs in making the compensation, fees and interest payments

17 PERFORMANCE BOND / ~~PERFORMANCE CASH DEPOSIT~~

17.1 Without expense to the County Council the Developer and the Performance Bond Surety shall on the date of this Agreement enter into the Performance Bond and Performance Bond Surety shall be bound to the County Council in the amount of the Performance Figure for the Highway Works

17.2 Should the Developer default in the execution of its obligations to carry out any or all of the Highway Works and to maintain the same in accordance with the provisions of this Agreement then the County Council may (subject to the provisions hereinafter contained) itself carry out the Highway Works and maintain the same as aforesaid having first called upon the Performance Bond Surety for the cost to be expended in so doing

17.2.1 Unless there is a danger to users of the highway the County Council shall give twenty (20) working days prior written notice (or lesser period as may in the circumstances be reasonable) of its intention to commence work under Paragraph 17.2

17.2.2 any notice served under this paragraph shall specify the period of the notice ("the Notice Period") the extent of the work which the County Council proposes to carry out and full details of all matters in respect of which the Director considers that the Highway Works have not been carried out in accordance with the terms of this Agreement

17.2.3 if before the expiry of the Notice Period the Developer serves written notice upon the County Council that the Developer intends diligently to execute the works specified in the notice in accordance with the terms of this Agreement and specifies a time to complete that the County Council considers reasonable in the circumstances the County Council shall not be entitled to execute the relevant part or parts of the Highway Works specified in the notice served under this paragraph unless the

Developer then fails to execute those works within the agreed time scale

17.3 If the Developer should default in the execution of its obligations to carry out any or all of the Highway Works and to maintain the same in accordance with the provisions of this Agreement then the County Council will call upon the Performance Bond Surety to provide the full Performance Figure (or such sum that remains following reduction of the Performance Bond in accordance with Paragraph 14.4 of this Schedule) in accordance with this Agreement. Save that the County Council after all works are completed and all contracts and any contract claims settled will return any Performance Bond sum unused with interest at the Bank of England Base Rate minus 2 basis points, compounding annually at financial year end on receipt of a written request to the Performance Bond Surety within one month of all the aforementioned completing and settling. If for any period the Bank of England Base Rate is at or below 0.02% then no interest shall be payable for that period by any party to this Agreement

18 COMMUTED SUMS FOR MAINTENANCE

18.1 Prior to the date of this Agreement the Developer shall pay to the County Council the Commuted Sums calculated as follows:

	£
Roads	3,940.50
Verges, Trees and Street Furniture	2,178.00

19 LEGAL AND ADMINISTRATIVE COSTS

19.1 The Developer shall pay to the County Council:-

19.1.1 the whole of the costs of the County Council's Legal Services Department in connection with the preparation and completion of this Agreement and these costs shall be payable prior to sealing of this Agreement;

- 19.1.2 interest at four per cent above the Bank of England Base Rate from time to time on any sum due to the County Council under this Agreement which is outstanding for more than twenty-eight (28) days from the date on which it was demanded or in the event that a dispute or difference regarding such payment is referred to arbitration pursuant to clause 4.1 of this Agreement the said twenty-eight (28) day period shall run from the date of the decision of the arbitrator (such interest to be charged on the amount outstanding each day from the date of issue of a written demand for any sum due or in the event that a dispute or difference regarding such payment is referred to arbitration pursuant to clause 4.1 of this Agreement such interest to be charged on the amount outstanding each day from the date of issue of the decision of the arbitrator)
- 19.1.3 The greater of £5000 (Five thousand pounds) or 7½% of the Performance Figure (excluding the costs associated with statutory undertakers work and traffic management) for the Highway Works towards the costs and expenses of the County Council of checking the design of each and all of the Highway Works and inspecting each and all of the Highway Works such sum shall be payable prior to sealing of this Agreement
- 19.1.4 the reasonable cost to the County Council of undertaking Road Safety Audits and also the cost of the safety checks of details submitted which sum shall be payable prior to the safety audit commencing
- 19.1.5 the cost of any temporary and permanent traffic regulation orders which sum shall be payable prior to any work on the making of such order being commenced
- 19.1.6 the full cost of any other road traffic orders required to facilitate the Highway Works which sum shall be payable prior to any work on the making of such order being commenced
- [19.1.8 the whole of the costs of the County Council in connection with surveying and assessing the land upon which the Highways Works are to be constructed and land in the vicinity of the

Highway Works as deemed necessary by the County Council in order to provide the Compensation Figure for the Compensation Bond, and these costs shall be payable prior to sealing of this Agreement]

20 PARTS I AND II OF THE LAND COMPENSATION ACT 1973

Part I and II Claims

20.1 On the date of this Agreement and without expense to the County Council the Developer shall pay the Compensation Cash Deposit to the County Council

20.2 The Compensation Cash Deposit shall provide that should the Developer default in any way in his obligation to pay to the County Council the sums specified in paragraph 16 of this Schedule the County Council may call upon the Compensation Cash Deposit to pay the sums due under paragraph 16 and paragraph 20.4 of this Schedule to the County Council or any shortfall in the event that some of the monies have already been paid to the County Council

Part I Claims - Depreciation Caused By Public Works

20.3 Upon the date which falls seven (7) years from the point at which the last of the Highway Works is first open to public traffic and if all duly made claims are settled the County Council will release the Developer from all subsisting obligations under the Compensation Cash Deposit and the remainder of the Cash Deposit shall be returned together with interest as applied at the Bank of England Base Rate minus 2 basis points, compounding annually at financial year end on receipt of a written request. If for any period the Bank of England Base Rate is at or below 0.02% then no interest shall be payable for that period by any party to this Agreement save that if all duly made claims are not settled all but an amount reasonably sufficient to settle such claims will be released

20.4 The Developer hereby undertakes and agrees with the County Council that in the event of any claim for compensation or otherwise or costs or charges arising in connection with or incidental to or in consequence of the carrying out of the Highway Works whether mandatory or discretionary which may be incurred by virtue of any enactment or

statutory instrument and otherwise hereby provided for he will hold the County Council fully indemnified from and against all claims charges costs and expenses in connection therewith or arising therefrom

Part II Claims

20.5 The Developer covenants with the County Council to comply with the requirements of the Noise Insulation Regulations 1975 (SI 1975/1763) as amended and to provide to the County Council such evidence as is required by the Director to demonstrate compliance with the Noise Insulation Regulations 1975 prior to the issuing by the County Council of the Certificate of Final Completion in accordance with paragraph 15.3 of this Schedule



SCHEDULE II.A

Performance Bond Agreement

DATED 7th June 2023 2023

BDW TRADING LIMITED (1)

- and -

NATIONAL HOUSE-BUILDING COUNCIL (2)

---

PERFORMANCE BOND

relating to the development of Land a Quintons Road, East Bergholt, Colchester,  
CO7 6RB, Suffolk

---

BY THIS BOND **BDW TRADING LIMITED** of Barratt House, Cartwright Way, Forest Business Park, Bardon Hill, Coalville, Leicestershire, LE67 1UF ("the Developer") and

**NATIONAL HOUSE-BUILDING COUNCIL** ("the Surety") are held and firmly bound to **SUFFOLK COUNTY COUNCIL** of Endeavour House 8 Russell Road Ipswich Suffolk IP1 2DH ("the County Council") in the sum of £462,000 (four hundred and sixty-two thousand pounds) to be paid to the County Council for the payment of which sum the Developer and the Surety bind themselves their successors and assigns jointly and severally

IN WITNESS whereof the Developer and the Surety have hereunto executed and delivered the same on but not before this 7<sup>th</sup> day of June Two thousand and twenty three

1. The Developer has entered into an Agreement under seal with the County Council of even date made under Section 278 of the 1980 Act whereby the Developer undertook at its own expense to carry out works as set out in Schedule III of the said Agreement and shown in the Works Drawings annexed to the said Agreement ("the Highway Works")
2. It is intended that this Bond shall be construed as one with the said Agreement

**NOW THE CONDITION** of the above-written Bond is such that if the Developer shall duly perform and observe all the terms provisions conditions and stipulations of the said Agreement (in so far as they relate to the Highway Works) on the Developer's part to be performed and observed according to the true intent and meaning thereof or if on default by the Developer the Surety shall duly satisfy and discharge the

damages sustained by the County Council up to the amount of the above-written Bond then the above-written Bond shall be null and void but otherwise shall remain in full force and effect **PROVIDED ALWAYS** that the giving by the County Council of any extension of time for performing the said Agreement or any stipulations therein contained and on the part of the Developer to be performed or any other forgiveness or forbearance on the part of the County Council or its successors or assigns shall not in any way release the Surety from any liability under the above-written Bond

EXECUTED AS A DEED BY BDW  
TRADING LIMITED in the presence  
of:

Director:

Director/Secretary:

Signed as a deed by ALYCE YALE as attorney for  
National House-Building Council under a Power of Attorney  
dated [ 30<sup>th</sup> march 2022 ]



Underwriting Team Leader – Road and Sewer bonds  
.....

As attorney for National House-Building Council

In the presence of:

Shannon Thomthwait Stomthwait  
.....

Name of Witness

Witness Signature

Occupation of Witness UW Manage  
.....

Address of Witness NHBC House,  
Davy Avenue, Knowlton, MKS 8FP

**SIGNED** as a **DEED** by

**Brandon Schmidt**

.....  
(Print name of Attorney)

as Attorney for

**BDW TRADING LIMITED**

in the presence of:

Witness Signature:

*Stewart Smith*  
.....

Name (in full):

*Stewart Smith*  
.....

Address c/o 7 Springfield Lyons Approach, Chelmsford, Essex CM2 5EY

and

**Dan Griffin**

.....  
(Print name of Attorney)

as Attorney for

**BDW TRADING LIMITED**

in the presence of:

Witness Signature:

*Stewart Smith*  
.....

Name (in full):

*Stewart Smith*  
.....

Address c/o 7 Springfield Lyons Approach, Chelmsford, Essex CM2 5EY

*Brandon Schmidt*  
.....  
(Sign here)

*Dan Griffin*  
.....  
(Sign here)

SCHEDULE III

The Highways Works comprising the following works:

<u>Location</u>	<u>Works</u>	<u>Delivery Programme</u>
<u>B1070/Road 1</u>	<u>Proposed Road 1 Junction to proposed Site, including footway improvement</u>	
<u>B1070/Road 2</u>	<u>Proposed Road 2 junction to proposed Site</u>	
<u>B1070/Road 3</u>	<u>Proposed Road 2 junction to proposed Site, including proposed bus stop lay-by, moving the existing bus stop and footway improvement</u>	
<u>B1070/Fiddlers Lane</u>	<u>New tactile crossing including footway improvement</u>	
<u>B1070/Fiddlers Lane</u>	<u>New tactile crossing, including footway improvement</u>	

Timescales: The Highways Works are to be commenced within 12 (twelve) months of the date of this Agreement and completed within 3 (three) months of commencement of the Highway Works

SCHEDULE IV

**Approved List of drawings**

	Title	Drawing number
1. ✓	H8771-3B-DE-200_278 Road Construction Sheet 1	1_FA_T3
2. ✓	H8771-3B-DE- <del>200</del> <sup>201</sup> -278 Road Construction Sheet 2	2_FA_T2
3. ✓	H8771-3B-DE- <del>200</del> <sup>202</sup> -278 Road Construction Sheets	2_FA_T3
4. ✓	H8771-3B-GA-100_278 Site Clearance Sheet 1	1_FA_T1
5. ✓	H8771-3B-GA-101_278 Site Clearance Sheet 2	1_FA_T2
6. ✓	H8771-3B-GA-102_278 Site Clearance Sheet 3	3_FA_T1
7. ✓	H8771-3B-GA-200_General Arrangement Sheet 1	1_FA_T2
8. ✓	H8771-3B-GA-201_General Arrangement Sheet 2	2_FA_T3
9. ✓	H8771-3B-GA-202_General Arrangement Sheet 3	3_FA-T2
10. ✓	H8771-3B-GA-210_Surface Finishes Sheet 1	1_FA_T2
11. ✓	H8771-3B-GA-211_Surface Finishes Sheet 2	2_FA_T <del>2</del> <sup>T3</sup>
12. ✓	H8771-3B-GA-212_Surface Finishes Sheet 3	3_FA_T <del>3</del> <sup>T1</sup>
13. ✓	H8771-3B-GA-220 Agreement Plan Sheet 1	1_FA_T2
14. ✓	H8771-3B-GA-221 Agreement Plan Sheet 2	2_FA_T3
15. ✓	H8771-3B-GA-222 Agreement Plan Sheet 3	3_FA_T2
16. ✓	H8771_3B-GA-223 Land Adoption	FA-T2
17. ✓	H8771_3B-GA-240 Minor Works Agreement (Road 1)	FA-T2 T1
18. ✓	H8771_3B-GA-250_S278 Setting out sheet 1	FA-T2
19. ✓	H8771_3B_GA-251_S278 Setting out sheet 2	FA_T3
20. ✓	H8771-3B-GA-252_S278 Setting Out Sheet 3	FA_T1
21. ✓	H8771_3B-SE-200_278 Long Sections	FA_T1





Curbs and frames shall comply with BS EN 124 Grade D400. All gullies shall be manufactured from cast or ductile iron, clearly marked with their name and the grade of gully and gully frame. The gully and gully frame shall be made of BS EN 124 Grade D400. The gully and gully frame shall be made of BS EN 124 Grade D400. The gully and gully frame shall be made of BS EN 124 Grade D400.

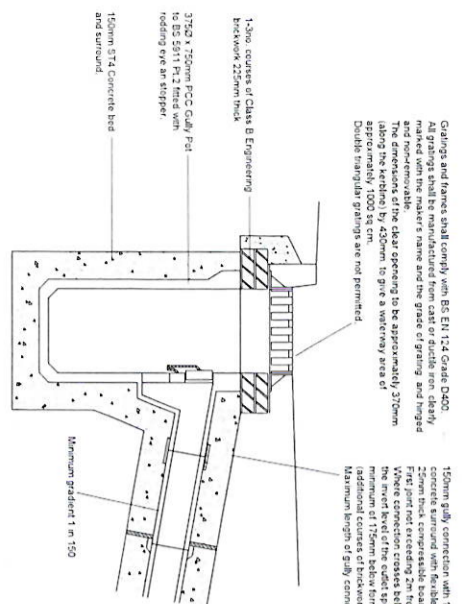

ROAD GULLY DETAIL  
NTS

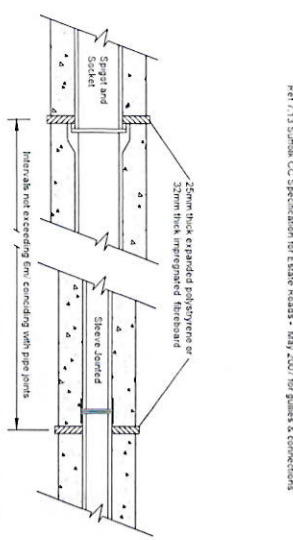

DETAIL OF FLEXIBLE JOINTS  
IN CONCRETE SURROUND  
NTS

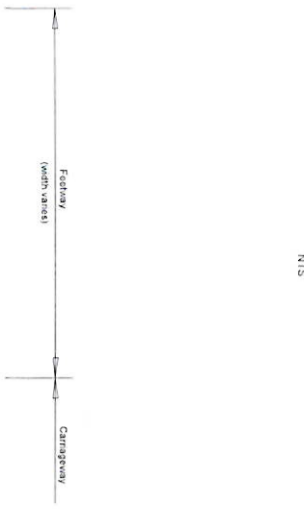

SECTION THROUGH TACTILE PAVED CROSSING  
SCALE 1:20

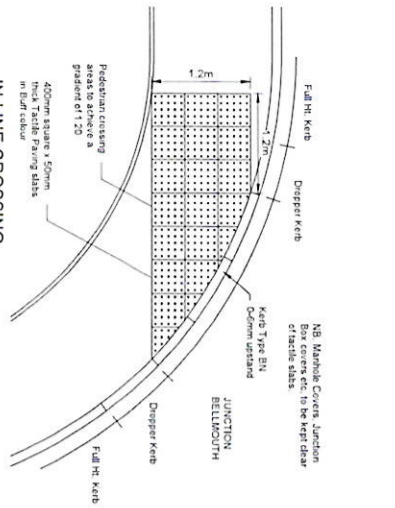

TACTILE PAVED PEDESTRIAN/PRAM CROSSINGS  
NTS

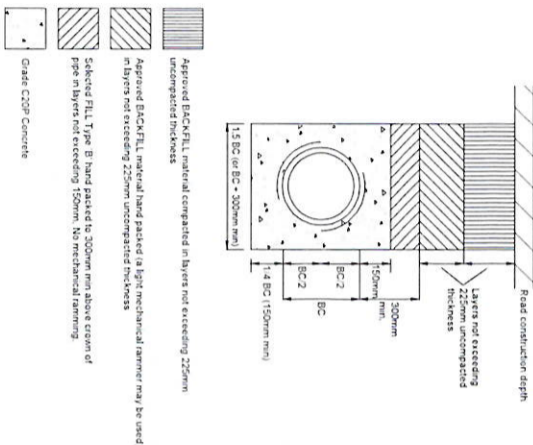

JOINT TO EXISTING CARRIAGEWAY DETAIL  
SCALE 1:20



SECTION THROUGH FOOTWAY WIDENING (CARRIAGEWAY CROSSFALL)  
(B1070/ GASTON END)  
SCALE 1:20

SECTION THROUGH FOOTWAY WIDENING (CARRIAGEWAY CAMBERED)  
(B1070/ GASTON END)  
SCALE 1:20

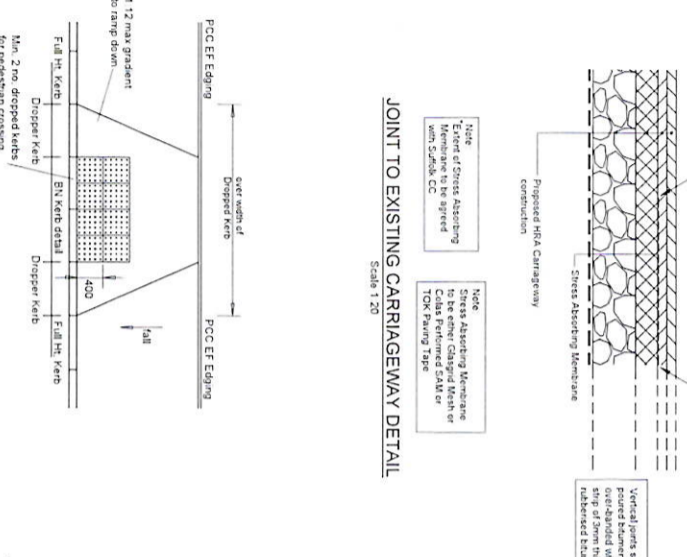

JOINT TO EXISTING CARRIAGEWAY DETAIL  
SCALE 1:20

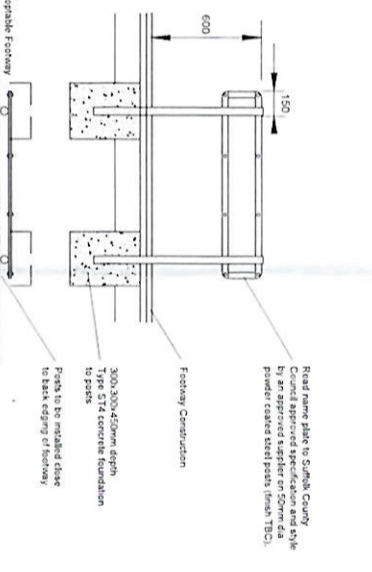

STREET NAME PLATE  
NTS

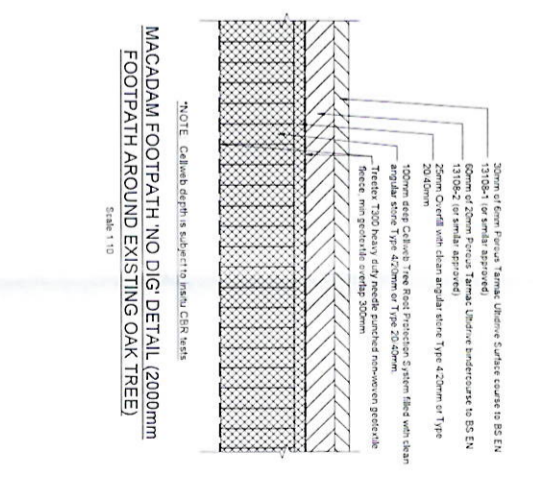

MACADAM FOOTPATH AND DIG DETAIL (2000mm)  
FOOTPATH AROUND EXISTING OAK TREE  
SCALE 1:10

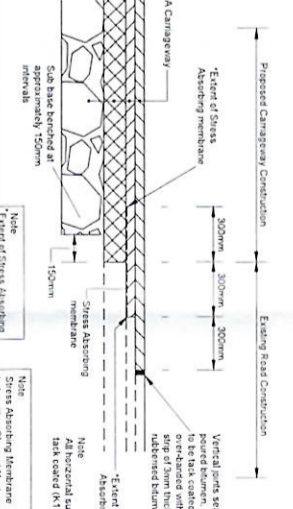

JOINT TO EXISTING CARRIAGEWAY DETAIL  
(3 Step Tie In)  
SCALE 1:20

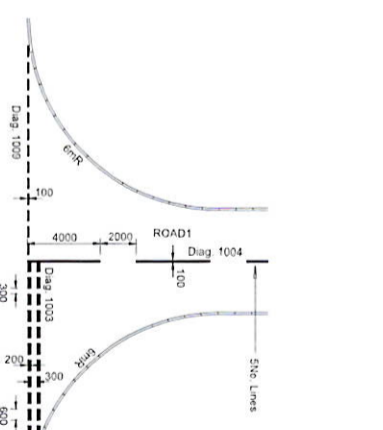

GIVE WAY MARKINGS SCHEMATIC  
SCALE 1:20

DIAG No	Size mm	Description
1003	600 x 200 200 gap 200 rows	Give way
1004	300 apart	Hazard marking
1005	4000 x 100 2000 gap	Edge of carriageway at a junction
1009	600 x 150 300 gap	Give way straight
1023	1250 x 3750 long	Give way straight

ROAD MARKINGS SCHEDULE

Dan Griffin

No Dimensions are to be scaled from this drawing.

- NOTES
- All dimensions in millimeters unless stated otherwise.
  - Curbs shall be made to BS EN 124 Grade D400. All gullies shall be manufactured from cast or ductile iron, clearly marked with their name and the grade of gully and gully frame. The gully and gully frame shall be made of BS EN 124 Grade D400. The gully and gully frame shall be made of BS EN 124 Grade D400.
  - Design CBR to be assumed as 5% but construction shall be to BS EN 13108 (2000) P2 and P20001 table B15 & B16.
  - CRB shall be required at formation level at 20m centres and where soil at formation level changes noticeably to determine required depths of sub base and nature of gradeable required (if any). If required over consolidated material ground under suitable areas to be to the Subbase Specification for CBR.
  - CRB shall be required at formation level at 20m centres and where soil at formation level changes noticeably to determine required depths of sub base and nature of gradeable required (if any). If required over consolidated material ground under suitable areas to be to the Subbase Specification for CBR.
  - CRB shall be required at formation level at 20m centres and where soil at formation level changes noticeably to determine required depths of sub base and nature of gradeable required (if any). If required over consolidated material ground under suitable areas to be to the Subbase Specification for CBR.
  - CRB shall be required at formation level at 20m centres and where soil at formation level changes noticeably to determine required depths of sub base and nature of gradeable required (if any). If required over consolidated material ground under suitable areas to be to the Subbase Specification for CBR.
  - CRB shall be required at formation level at 20m centres and where soil at formation level changes noticeably to determine required depths of sub base and nature of gradeable required (if any). If required over consolidated material ground under suitable areas to be to the Subbase Specification for CBR.
  - CRB shall be required at formation level at 20m centres and where soil at formation level changes noticeably to determine required depths of sub base and nature of gradeable required (if any). If required over consolidated material ground under suitable areas to be to the Subbase Specification for CBR.
  - CRB shall be required at formation level at 20m centres and where soil at formation level changes noticeably to determine required depths of sub base and nature of gradeable required (if any). If required over consolidated material ground under suitable areas to be to the Subbase Specification for CBR.

TABLE 1: SUBBASE THICKNESSES

CBR	Minor Road	Single Road
5%	400mm	300mm
7.5%	300mm	200mm
10%	200mm	150mm

REVISIONS

NO	DESCRIPTION	DATE	BY
P1	Preliminary issue	04/07/22	nas
P2	Drawing number changed 'No Dig' footway	07/07/22	nas
P3	Joint to existing carriageway detail added	28/07/22	nas
T1	Tender issue	12/08/22	cab
T2	Change details update (labelling manufacturer)	25/11/22	cab

Brandon Schmidt

WITHERS  
DESIGN ASSOCIATES

CIVIL ENGINEERING & INFRASTRUCTURE DESIGN  
Unit 12, Water Lane Business Centre  
Water Lane, Colchester Essex  
CO2 2DY  
0206 240081

DAVID WILSON HOMES  
WHERE QUALITY LIVES

PROJECT  
MOORES LANE, EAST BERGHOLT  
SUFFOLK.

SECTION 278  
ROAD CONSTRUCTION DETAILS  
Sheet 2

SCALE DATE N/A N/A

AS SHOWN 06/12/22 nas cb

TENDER

DWG NO H8771-3B-DE-201

REVISION 12

No Dimensions are to be scaled from this drawing.

- NOTES**
1. All dimensions in millimetres unless stated otherwise.
  2. Applicable to all roads within the South East of the County Council jurisdiction.
  3. Design CBR is to be assumed as 5% but road construction shall be designed to meet the requirements of the relevant specification.
  4. CBR tests will be required at formation level at 30m centres and where soil at formation level changes noticeably, to determine any further requirements.
  5. Any fill required over consolidated natural ground under suitable areas is to be to the South Highway Specification for stopping All Works on and in vicinity of Public Highway to be in accordance with the requirements of South Highway subject to notice under the New Road and Street Works Act and traffic management and personnel must be supervised by appropriately accredited personnel.
  6. Purpose made status kerbs are to be used where kerb radius is 12m or less.
  7. Kerb radius is to be in accordance with BS1373 Part 3 Code of Practice for kerbs.
  8. Kerb bedding is to be in accordance with Class II 7 table D.1.
  9. Sand bedding is to be in accordance with Class II 7 table D.1.
  10. The formation of all structural paving is to be proof roller and any seal coat to be removed.
  11. The base material to conform the design team's recommended values identified in the site reports.
  12. Kerb bedding is to be in accordance with Class II 7 table D.1 (min) vehicle loads. Areas accessible for fire tender access are in excess of 3.7m width and height clearance.
  13. Sub base shall be DOT Type 1 granular material to MCHV 803 except where shown otherwise and is comply with the requirements of the South Highway Specification for Earth Roadwork Class 2.3 sub base Table 1 below and note 3 above.
  14. All unbound materials to be designed to DOT 1 as a sub base 30% CBR. Granular and subbase materials to be tested in accordance with BS1373 Part 3 Code of Practice for sub base. All rooms within the carriageway to have 150mm deep frame (inadequate covers, gully gratings etc).
  15. All dimensions are to be scaled from this drawing.

**TABLE 1: SUBBASE THICKNESS**

Where CBR values of subbase are less than 5% the following sub grade thicknesses may be specified

CBR	Min. Access	Standard Surface
5%	200mm	200mm
2%	420mm	370mm
3%	320mm	280mm
4%	250mm	220mm

For CBR of less than 2% seek further guidance  
Ref: Table 9.2 of CEC Earth Road Specification May 2007

**NOTE**  
THIS DRAWING IS FOR GUIDANCE ONLY.  
REFER TO SUFFOLK COUNTY COUNCIL SPECIFICATION FOR  
ESTATE ROADS (MAY 2007) FOR FULL REQUIREMENTS

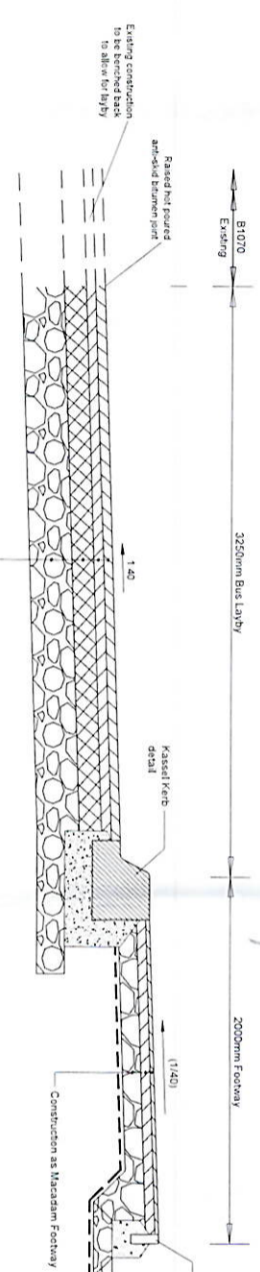
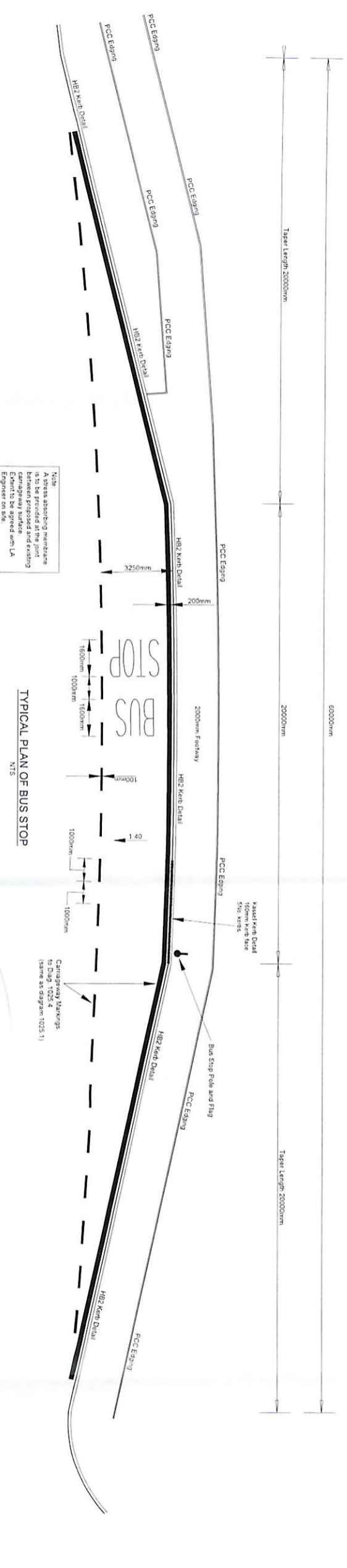

**NOTE**  
A stress absorbing membrane is to be provided at the joint between proposed and existing kerbs. Details to be agreed with LA Engineer on site.

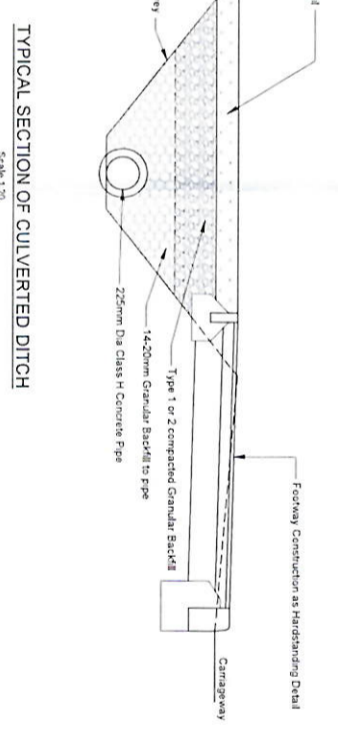
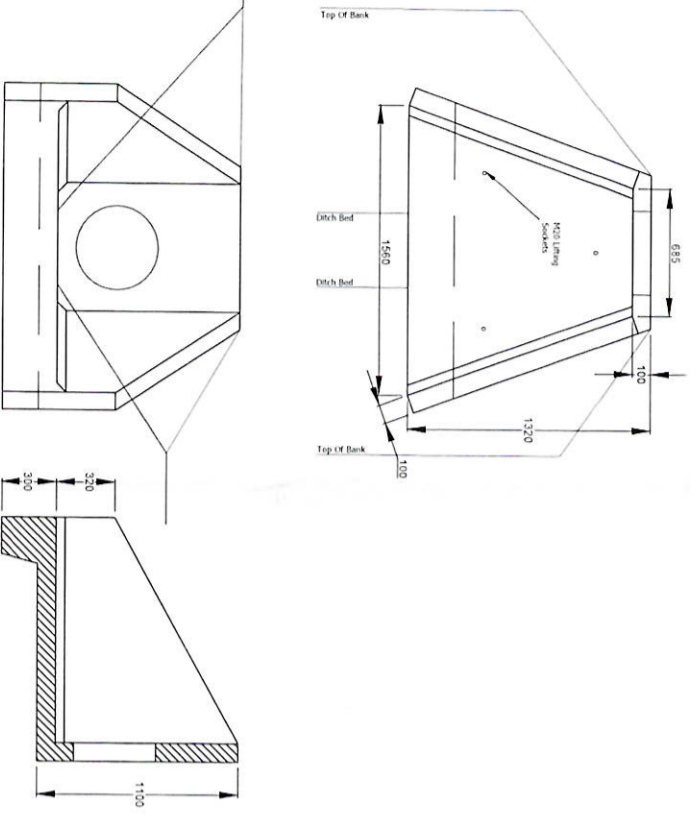
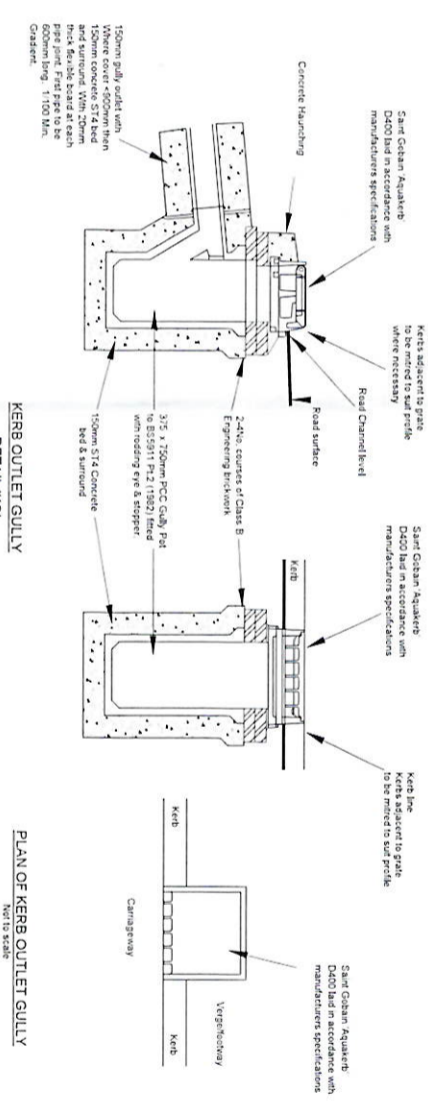

*Dan Griffin*  
Dan Griffin

**REVISIONS**

NO.	DESCRIPTION	DATE	BY	CHECKED
1	Preparatory issue	04/07/22	NAS	CB
2	Design amended to include details as per	21/07/22	NAS	CB
3	Final issue	12/08/22	NAS	CB
4	Final issue revised for Typical Plan of Bus Stop	25/11/22	NAS	CB
5	Final issue revised for Typical Plan of Bus Stop	25/11/22	NAS	CB
6	Final issue revised for Typical Plan of Bus Stop	16/03/23	NAS	CB

**CLIENT:** DAVID WILSON HOMES  
WHERE QUALITY LIVES

**PROJECT:** MOORES LANE, EAST BERGHOLT SUFFOLK.

**DESIGNER:** WITHERS  
CIVIL ENGINEERING & INFRASTRUCTURE DESIGN  
Unit 12, Wymen Hall Business Centre  
Wymen Close, Colchester, Essex  
CO2 2DY  
01206 250081

**SCALE:** AS SHOWN @ 1:50  
**DATE:** 06/22  
**TENDER:** NAS  
**STATUS:** CB  
**DWG NO:** H8771-3B-DE-202  
**REVISION:** T3





No Dimensions are to be scaled from this drawing.

LEGEND

	Existing Tree
	Existing Property Fridge
	Existing Property Fridge to be removed
	Existing Carport to be removed
	Existing Carport to be retained
	Existing Footway to be removed
	Existing Footway to be retained
	Existing Road to be removed
	Existing Road to be retained
	Existing Sewer
	Existing Gas Main
	Existing Water Main
	Existing Drainage
	Existing Street (single lane)
	Existing Street (dual lane)
	Existing Boundary
	Site Boundary

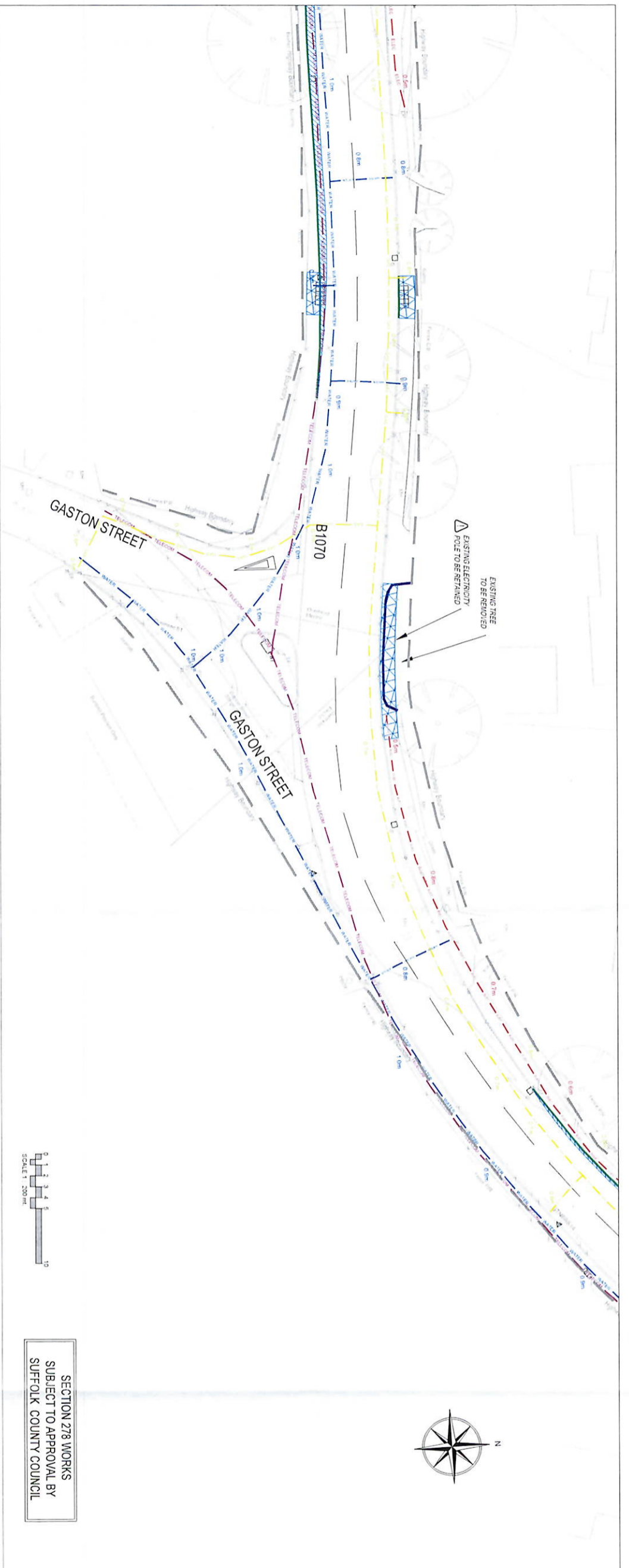

SECTION 278 WORKS  
SUBJECT TO APPROVAL BY  
SUFFOLK COUNTY COUNCIL



SECTION 278 WORKS  
SUBJECT TO APPROVAL BY  
SUFFOLK COUNTY COUNCIL

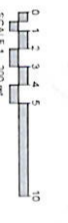

<p>PROJECT: MOORES LANE, EAST BERGHOLT SUFFOLK.</p> <p>CLIENT: DAVID WILSON HOMES</p> <p>ARCHITECT: BRANDON SCHMIDT</p> <p>ENGINEER: DAN GRIFFIN</p> <p>DESIGNER: WITHERS</p> <p>WITHERS CIVIL ENGINEERING &amp; INFRASTRUCTURE DESIGN Unit 12, Waters Hill Business Centre Waters Close, Colchester, Essex CO2 2JN 0206 249181</p>		<p>DATE: 07/22</p> <p>STATUS: M&amp;S</p> <p>TENDER: CH</p> <p>REF: H8771-3B-GA-102</p> <p>VERSION: T1</p>
---	--	--

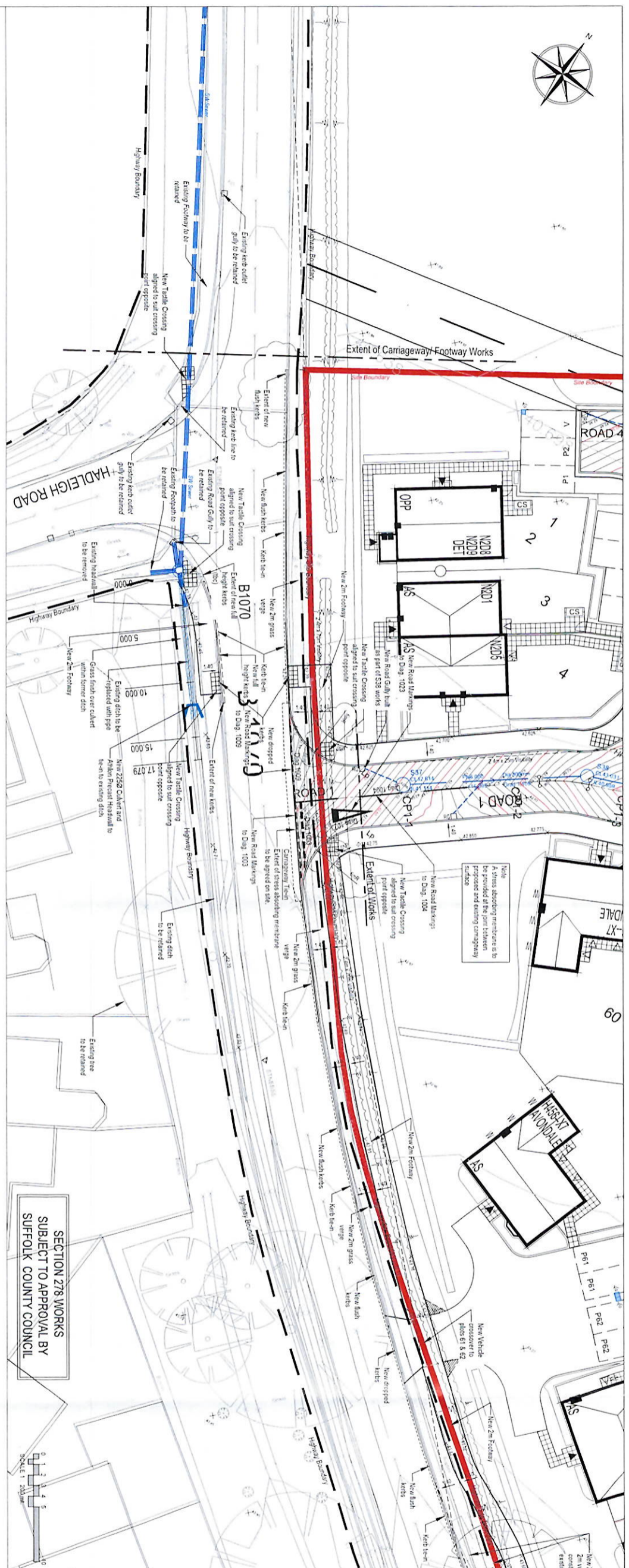

SECTION 278 WORKS  
SUBJECT TO APPROVAL BY  
SUFFOLK COUNTY COUNCIL

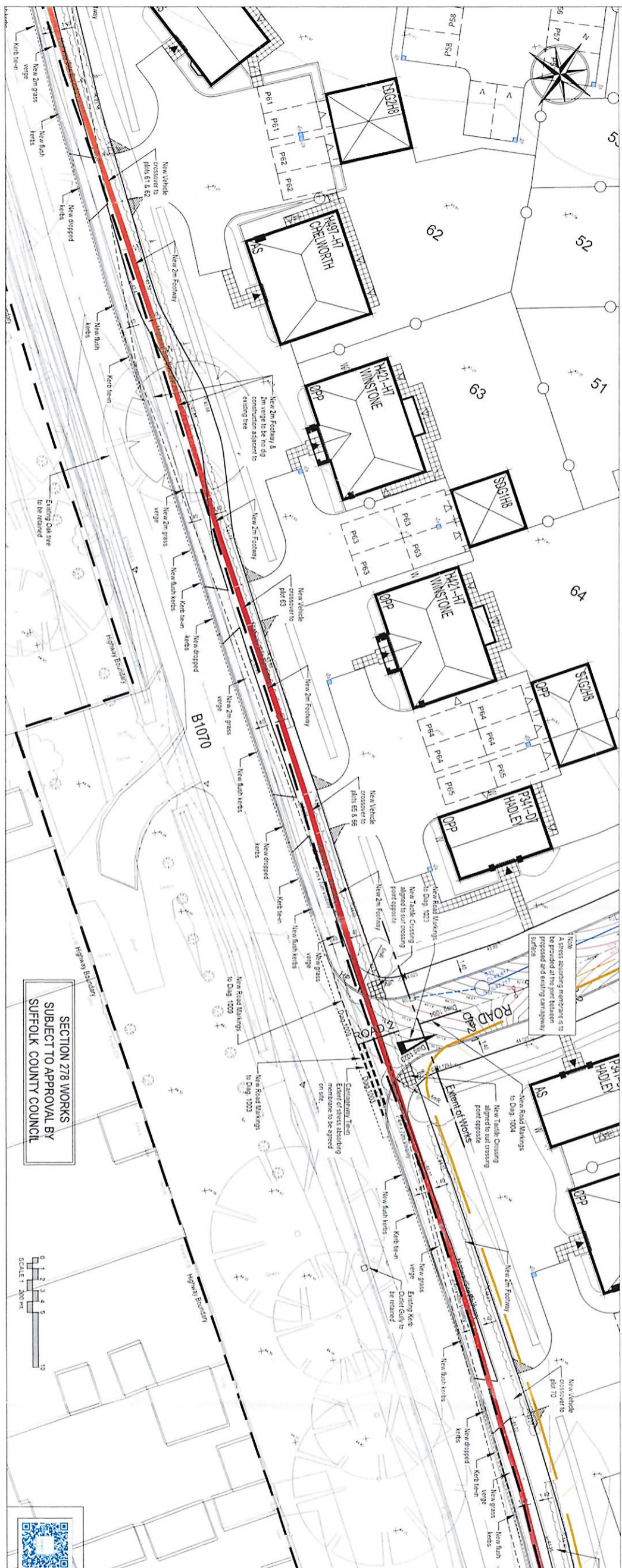
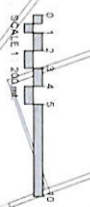

SECTION 278 WORKS  
SUBJECT TO APPROVAL BY  
SUFFOLK COUNTY COUNCIL

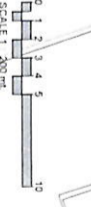

No Dimensions are to be scaled from this drawing.

- NOTES**
- All work shall be carried out in accordance with the Highway Act 1980 and the Traffic Signs Regulations and General Directions 2002.
  - The contractor is responsible for obtaining all necessary permits for works in the highway and for ensuring that the highway is kept open as far as possible.
  - Any existing trees or structures which are to be removed shall be retained where possible and replaced as far as possible.
  - Any existing trees or structures which are to be removed shall be retained where possible and replaced as far as possible.
  - Any existing trees or structures which are to be removed shall be retained where possible and replaced as far as possible.
  - Any existing trees or structures which are to be removed shall be retained where possible and replaced as far as possible.
  - Any existing trees or structures which are to be removed shall be retained where possible and replaced as far as possible.
  - Any existing trees or structures which are to be removed shall be retained where possible and replaced as far as possible.
  - Any existing trees or structures which are to be removed shall be retained where possible and replaced as far as possible.
  - Any existing trees or structures which are to be removed shall be retained where possible and replaced as far as possible.
  - Any existing trees or structures which are to be removed shall be retained where possible and replaced as far as possible.
  - Any existing trees or structures which are to be removed shall be retained where possible and replaced as far as possible.
  - Any existing trees or structures which are to be removed shall be retained where possible and replaced as far as possible.
  - Any existing trees or structures which are to be removed shall be retained where possible and replaced as far as possible.
  - Any existing trees or structures which are to be removed shall be retained where possible and replaced as far as possible.
  - Any existing trees or structures which are to be removed shall be retained where possible and replaced as far as possible.

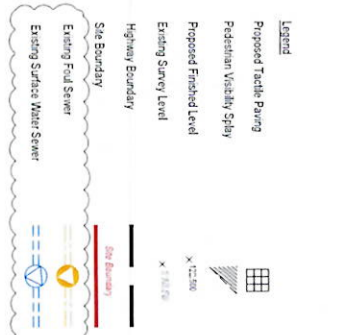

**KNOWON**

Preparation Date	06/22
Issue No.	01
Author	MS
Checker	MS
Approver	MS
Project No.	1200 @A1
Sheet No.	06/22
Scale	N/S
Drawn	M/W
Checked	M/W
Approved	M/W

**Dan Griffin**

**Brandon Schmitt**

**W WITHERS**

CIVIL ENGINEERING & INFRASTRUCTURE DESIGN

Unit 12, Wilton Hill Business Centre  
Wilton, Colchester, Essex  
CO2 2DY  
0206 247061

**DAVID WILSON HOMES**

WHERE QUALITY LIVES

**MOORS LANE, EAST BERGHOLT  
SUFFOLK.**

**SECTION 278  
GENERAL ARRANGEMENT  
Sheet 1**

SCALE: DATE: 1:200 @A1 06/22

TENDER: DESIGN: H8771-3B-GA-200

STATUS: DATE: 06/22

DESIGNER: M/W

CHECKER: M/W

APPROVER: M/W

SCALE: DATE: 06/22

TENDER: DESIGN: H8771-3B-GA-200

STATUS: DATE: 06/22

DESIGNER: M/W

CHECKER: M/W

APPROVER: M/W

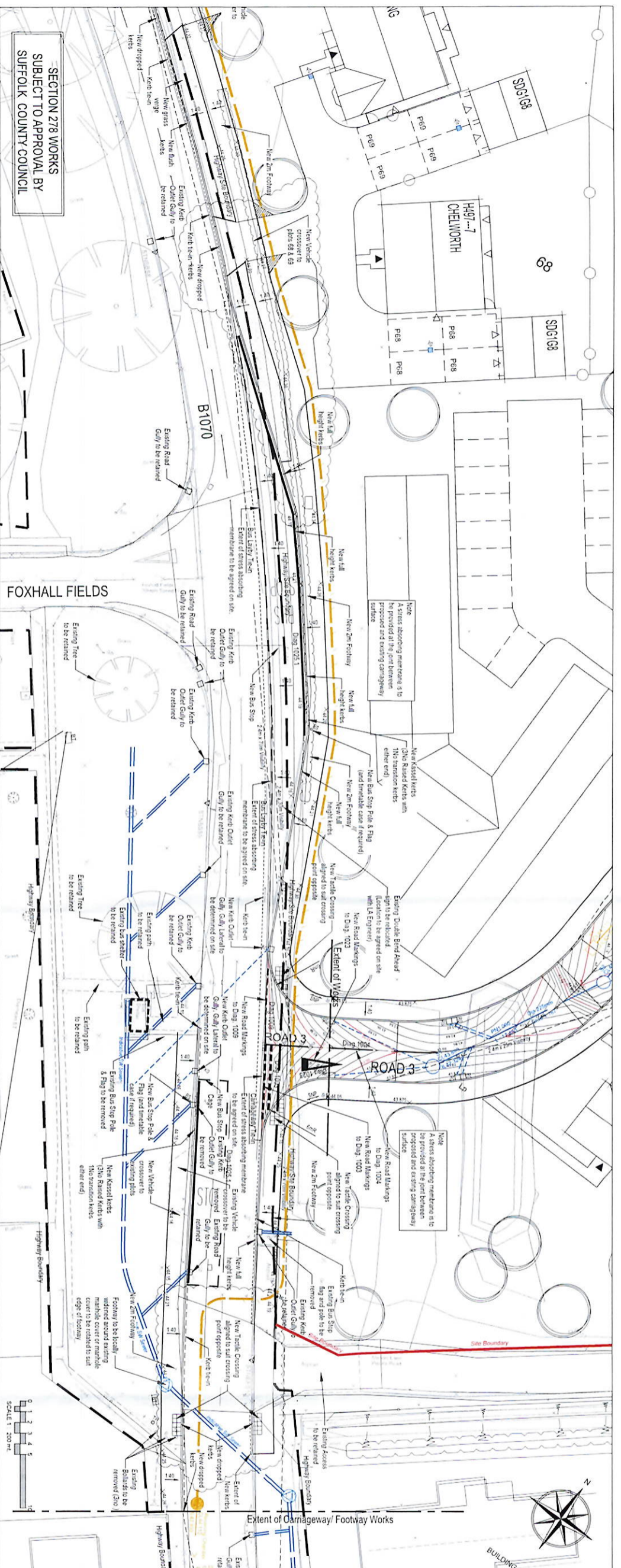

No Dimensions are to be scaled from this drawing.

- NOTES
1. All works shown on this plan shall be carried out in accordance with the Highway Act 1980 and the Highways Regulations 2004.
  2. The contractor is responsible for obtaining all necessary permits from the relevant authorities.
  3. The contractor shall be responsible for obtaining all necessary permits from the relevant authorities.
  4. The contractor shall be responsible for obtaining all necessary permits from the relevant authorities.
  5. The contractor shall be responsible for obtaining all necessary permits from the relevant authorities.
  6. The contractor shall be responsible for obtaining all necessary permits from the relevant authorities.
  7. The contractor shall be responsible for obtaining all necessary permits from the relevant authorities.
  8. The contractor shall be responsible for obtaining all necessary permits from the relevant authorities.
  9. The contractor shall be responsible for obtaining all necessary permits from the relevant authorities.
  10. The contractor shall be responsible for obtaining all necessary permits from the relevant authorities.
  11. The contractor shall be responsible for obtaining all necessary permits from the relevant authorities.
  12. The contractor shall be responsible for obtaining all necessary permits from the relevant authorities.
  13. The contractor shall be responsible for obtaining all necessary permits from the relevant authorities.
  14. The contractor shall be responsible for obtaining all necessary permits from the relevant authorities.
  15. The contractor shall be responsible for obtaining all necessary permits from the relevant authorities.
  16. The contractor shall be responsible for obtaining all necessary permits from the relevant authorities.
  17. The contractor shall be responsible for obtaining all necessary permits from the relevant authorities.
  18. The contractor shall be responsible for obtaining all necessary permits from the relevant authorities.
  19. The contractor shall be responsible for obtaining all necessary permits from the relevant authorities.
  20. The contractor shall be responsible for obtaining all necessary permits from the relevant authorities.

Legend	Proposed Trench Paving	Proposedkerb
Proposedkerb	Proposedkerb	Proposedkerb
Proposedkerb	Proposedkerb	Proposedkerb
Proposedkerb	Proposedkerb	Proposedkerb
Proposedkerb	Proposedkerb	Proposedkerb
Proposedkerb	Proposedkerb	Proposedkerb
Proposedkerb	Proposedkerb	Proposedkerb
Proposedkerb	Proposedkerb	Proposedkerb
Proposedkerb	Proposedkerb	Proposedkerb
Proposedkerb	Proposedkerb	Proposedkerb

REVISIONS

No.	Description	Date
1	Issued for approval	06/22
2	Issued for approval	06/22
3	Issued for approval	06/22
4	Issued for approval	06/22
5	Issued for approval	06/22
6	Issued for approval	06/22
7	Issued for approval	06/22
8	Issued for approval	06/22
9	Issued for approval	06/22
10	Issued for approval	06/22
11	Issued for approval	06/22
12	Issued for approval	06/22
13	Issued for approval	06/22

Brandon Schmidt  
Civil Engineer

**W WITHERS**  
DESIGN ASSOCIATES  
Unit 12, Walden Hall Business Centre  
Walden, Colchester, Essex  
CO2 2DY  
0206 247081

**DAVID WILSON HOMES**  
WHERE QUALITY LIVES

SECTION 278 WORKS  
GENERAL ARRANGEMENT  
Sheet 2

DATE: 06/22  
DRAWN: NRS  
CHECKED: MAW  
SCALE: 1:200

DRAWING TITLE  
PROJECT  
CLIENT  
SITE  
STATUS  
TENDER  
DRAWING NO.  
REVISION

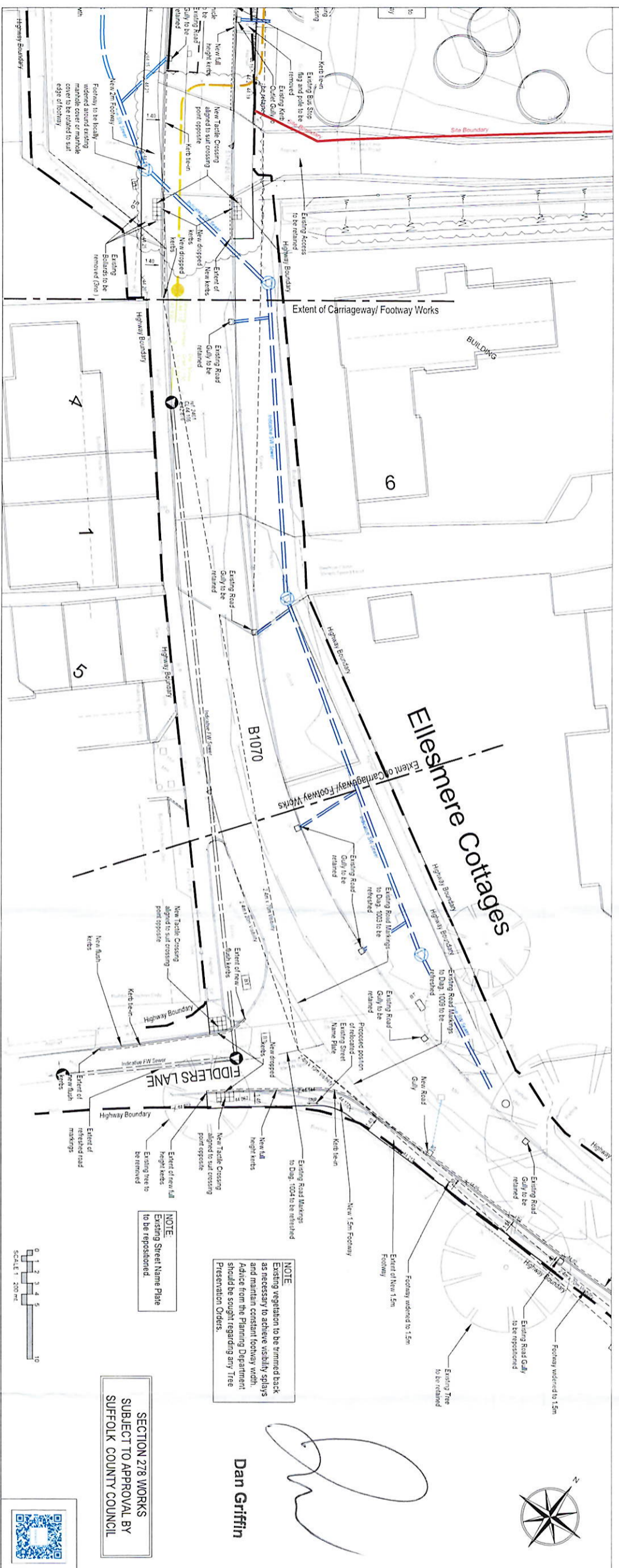

Dan Griffin

SECTION 278 WORKS  
SUBJECT TO APPROVAL BY  
SUFFOLK COUNTY COUNCIL

SECTION 278 WORKS  
GENERAL ARRANGEMENT  
Sheet 2

DATE: 06/22  
DRAWN: NRS  
CHECKED: MAW  
SCALE: 1:200

DRAWING TITLE  
PROJECT  
CLIENT  
SITE  
STATUS  
TENDER  
DRAWING NO.  
REVISION

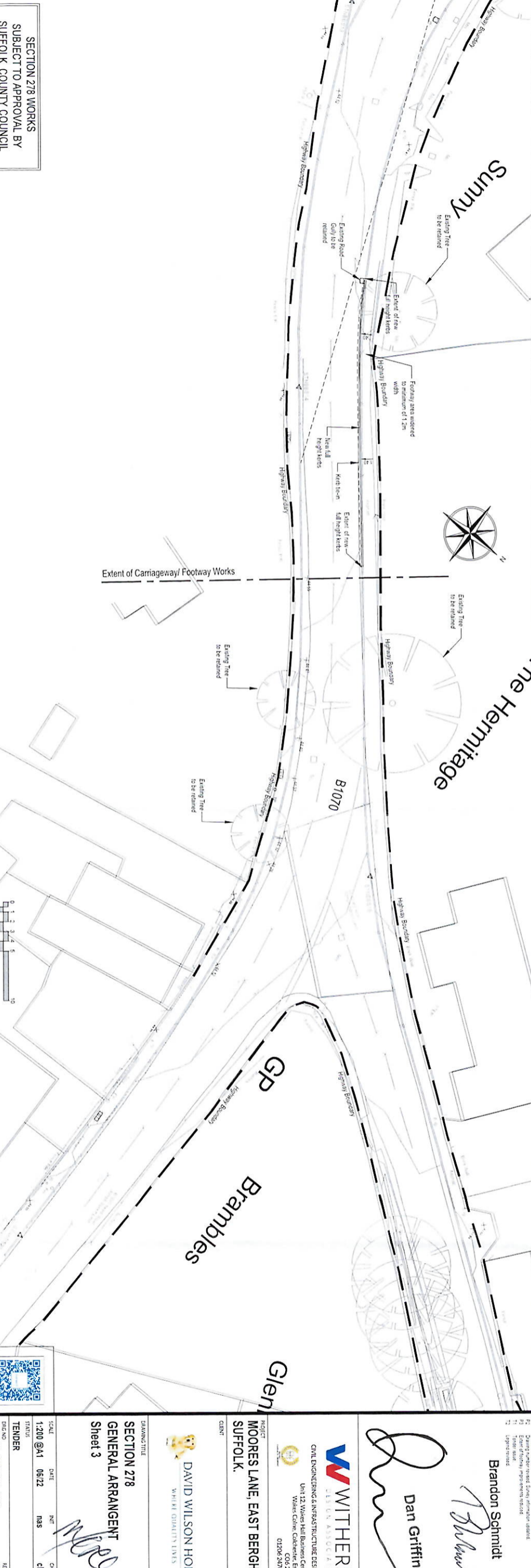
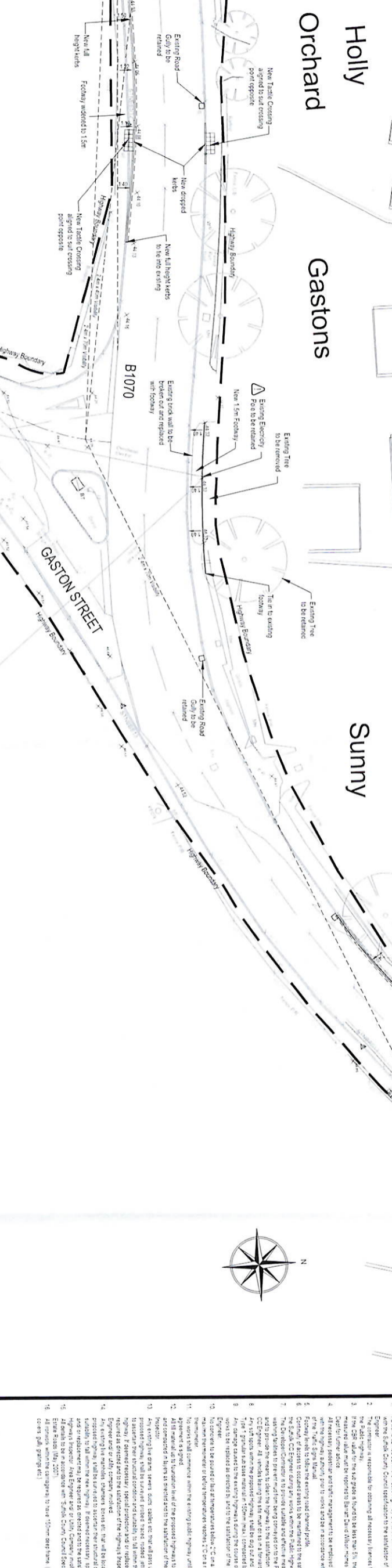

No Dimensions are to be scaled from this drawing

NOTES

- All works shown on the Public Highway are to be carried out in accordance with the Suffolk County Council (Suffolk Highways) Regulations 2019.
- The contractor is responsible for obtaining all necessary permits for works on the Public Highway.
- The SRS value for the site is to be determined by the contractor in accordance with the SRS Code of Practice.
- All vegetation to be removed must be replaced to the satisfaction of the Highway Authority.
- The Highway Authority must be notified of all works in accordance with Chapter 6 of the Traffic Signs Manual.
- Footway works shall be carried out during the night.
- The Highway Authority must be notified of all works on the Public Highway in accordance with the Traffic Signs Manual.
- The Highway Authority must be notified of all works on the Public Highway in accordance with the Traffic Signs Manual.
- The Highway Authority must be notified of all works on the Public Highway in accordance with the Traffic Signs Manual.
- The Highway Authority must be notified of all works on the Public Highway in accordance with the Traffic Signs Manual.
- The Highway Authority must be notified of all works on the Public Highway in accordance with the Traffic Signs Manual.
- The Highway Authority must be notified of all works on the Public Highway in accordance with the Traffic Signs Manual.
- The Highway Authority must be notified of all works on the Public Highway in accordance with the Traffic Signs Manual.
- The Highway Authority must be notified of all works on the Public Highway in accordance with the Traffic Signs Manual.
- The Highway Authority must be notified of all works on the Public Highway in accordance with the Traffic Signs Manual.
- The Highway Authority must be notified of all works on the Public Highway in accordance with the Traffic Signs Manual.



**Revision**

Rev	Description	Date
01	Issue for Tender	2022/08/11
02	Issue for Construction	2022/08/11
03	Issue for Construction	2022/08/11
04	Issue for Construction	2022/08/11
05	Issue for Construction	2022/08/11

**Brandon Schmidt**  
Dan Griffin

**WITHERS**  
PLANNING ASSOCIATES

CIVIL ENGINEERING & INFRASTRUCTURE DESIGN

Unit 12 Waters Hall Business Centre  
Waters Colne, Colchester, Essex  
CO2 0DQ  
01206 549201

**DAVID WILSON HOMES**  
WHERE QUALITY LIVES

PROJECT: MOORES LANE, EAST BERGHOLT  
SUFFOLK.

**SECTION 278 GENERAL ARRANGEMENT**  
Sheet 3

SCALE: 1:200 @ A1 06/22  
TENDER: H8771-3B-GA-202

SECTION 278 WORKS  
SUBJECT TO APPROVAL BY  
SUFFOLK COUNTY COUNCIL





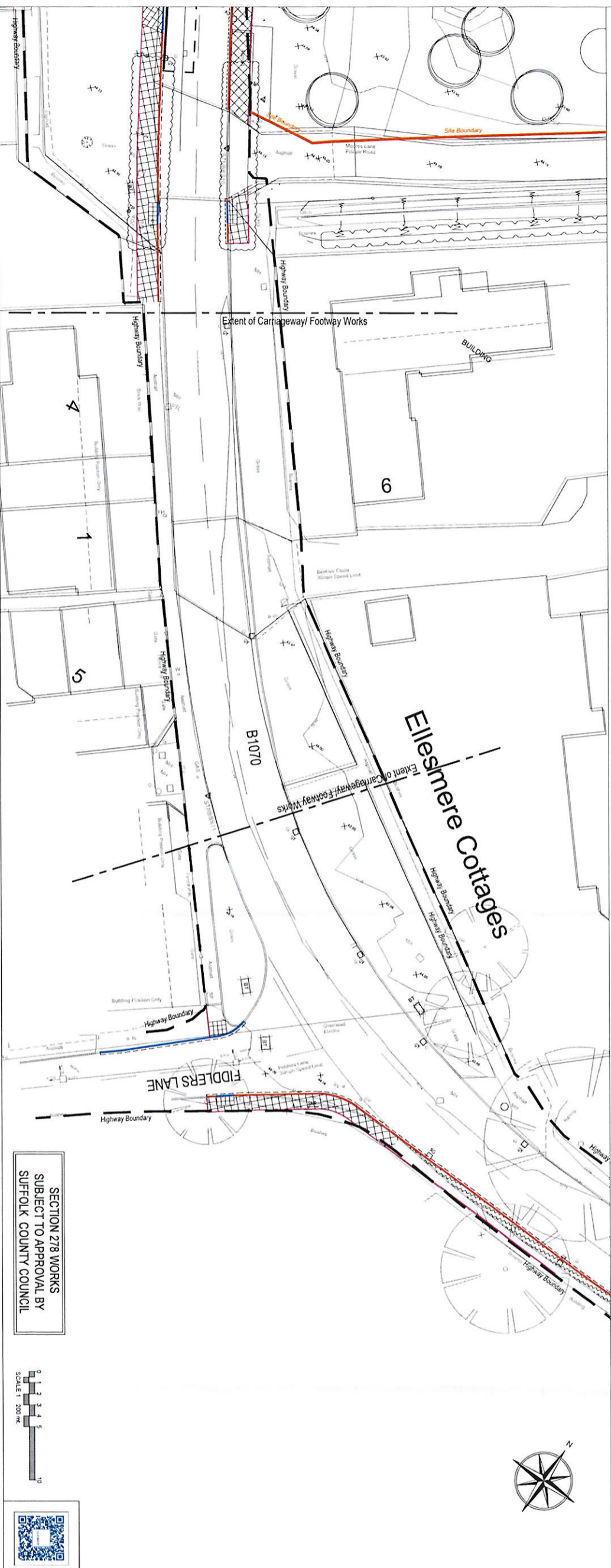
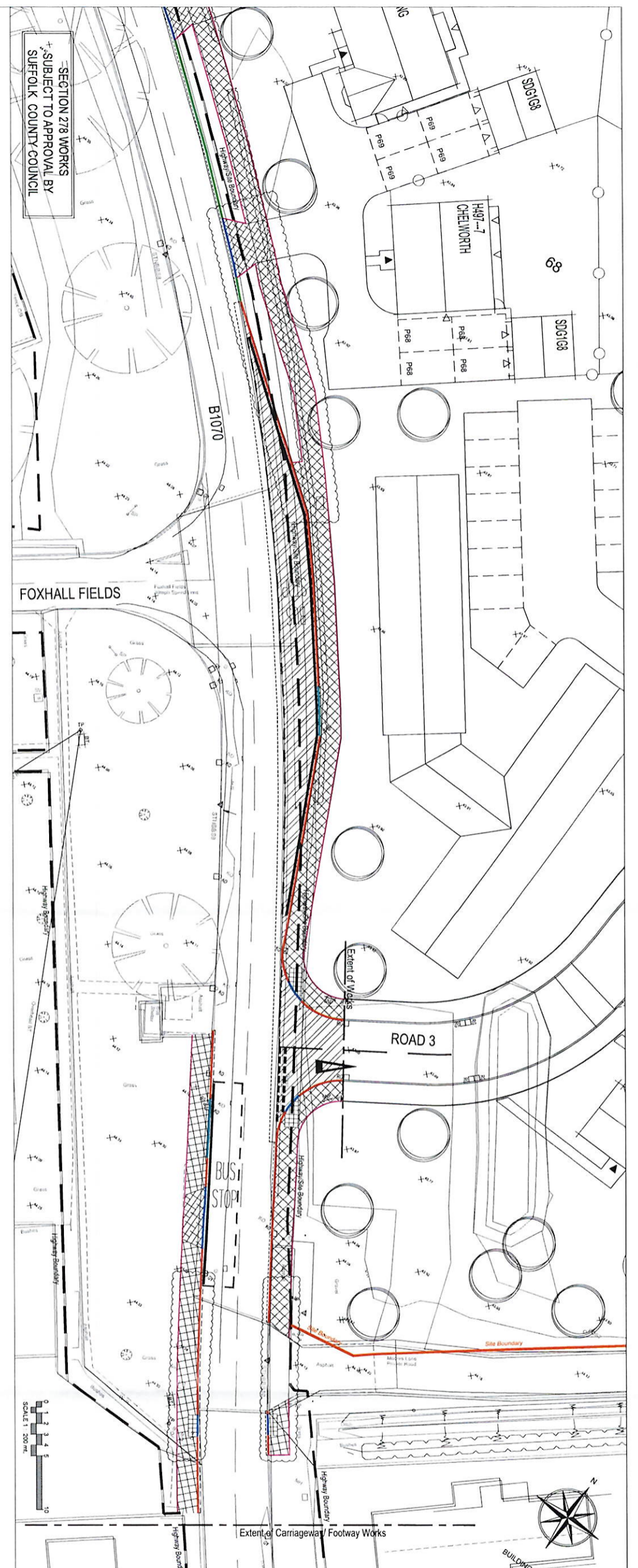

**NOTES**  
 1. All works carried out on the Public Highway are to be carried out in accordance with the Suffolk County Council specification to the satisfaction of the Highways Engineer.  
 2. The Engineer is responsible for obtaining all necessary permits for works on the Public Highway.  
 3. The Contractor shall be responsible for obtaining all necessary permits for works on the Public Highway.  
 4. The Contractor shall be responsible for obtaining all necessary permits for works on the Public Highway.  
 5. The Contractor shall be responsible for obtaining all necessary permits for works on the Public Highway.  
 6. The Contractor shall be responsible for obtaining all necessary permits for works on the Public Highway.  
 7. The Contractor shall be responsible for obtaining all necessary permits for works on the Public Highway.  
 8. The Contractor shall be responsible for obtaining all necessary permits for works on the Public Highway.  
 9. The Contractor shall be responsible for obtaining all necessary permits for works on the Public Highway.  
 10. The Contractor shall be responsible for obtaining all necessary permits for works on the Public Highway.  
 11. The Contractor shall be responsible for obtaining all necessary permits for works on the Public Highway.  
 12. The Contractor shall be responsible for obtaining all necessary permits for works on the Public Highway.  
 13. The Contractor shall be responsible for obtaining all necessary permits for works on the Public Highway.  
 14. The Contractor shall be responsible for obtaining all necessary permits for works on the Public Highway.  
 15. The Contractor shall be responsible for obtaining all necessary permits for works on the Public Highway.

NO.	DESCRIPTION	DATE	BY
1	Issue for approval	06/22	MBW
2	Revised	06/22	MBW
3	Revised	06/22	MBW
4	Revised	06/22	MBW
5	Revised	06/22	MBW
6	Revised	06/22	MBW
7	Revised	06/22	MBW
8	Revised	06/22	MBW
9	Revised	06/22	MBW
10	Revised	06/22	MBW
11	Revised	06/22	MBW
12	Revised	06/22	MBW
13	Revised	06/22	MBW
14	Revised	06/22	MBW
15	Revised	06/22	MBW

**MOORES LANE, EAST BERGHOLT SUFFOLK.**

**CLIENT**  
 DAVID WILSON HOMES  
 WHERE QUALITY LIVES

**PROJECT**  
 SURFACE FINISHES  
 Sheet 2

**SCALE**  
 1:200 @ A1 06/22 MBW  
 STATUS: TENDER  
 DRAWING NO: H8771-3B-GA-211  
 EDITION: 13

**WITHERS DESIGN ASSOCIATES**  
 CIVIL ENGINEERING & INFRASTRUCTURE DESIGN  
 Unit 12, Waters Hill Business Centre  
 Waters Close, Colchester, Essex  
 CO3 2DT  
 01206 547081

**REVISIONS**

NO.	DESCRIPTION	DATE	BY
1	Issue for approval	06/22	MBW
2	Revised	06/22	MBW
3	Revised	06/22	MBW
4	Revised	06/22	MBW
5	Revised	06/22	MBW
6	Revised	06/22	MBW
7	Revised	06/22	MBW
8	Revised	06/22	MBW
9	Revised	06/22	MBW
10	Revised	06/22	MBW
11	Revised	06/22	MBW
12	Revised	06/22	MBW
13	Revised	06/22	MBW
14	Revised	06/22	MBW
15	Revised	06/22	MBW



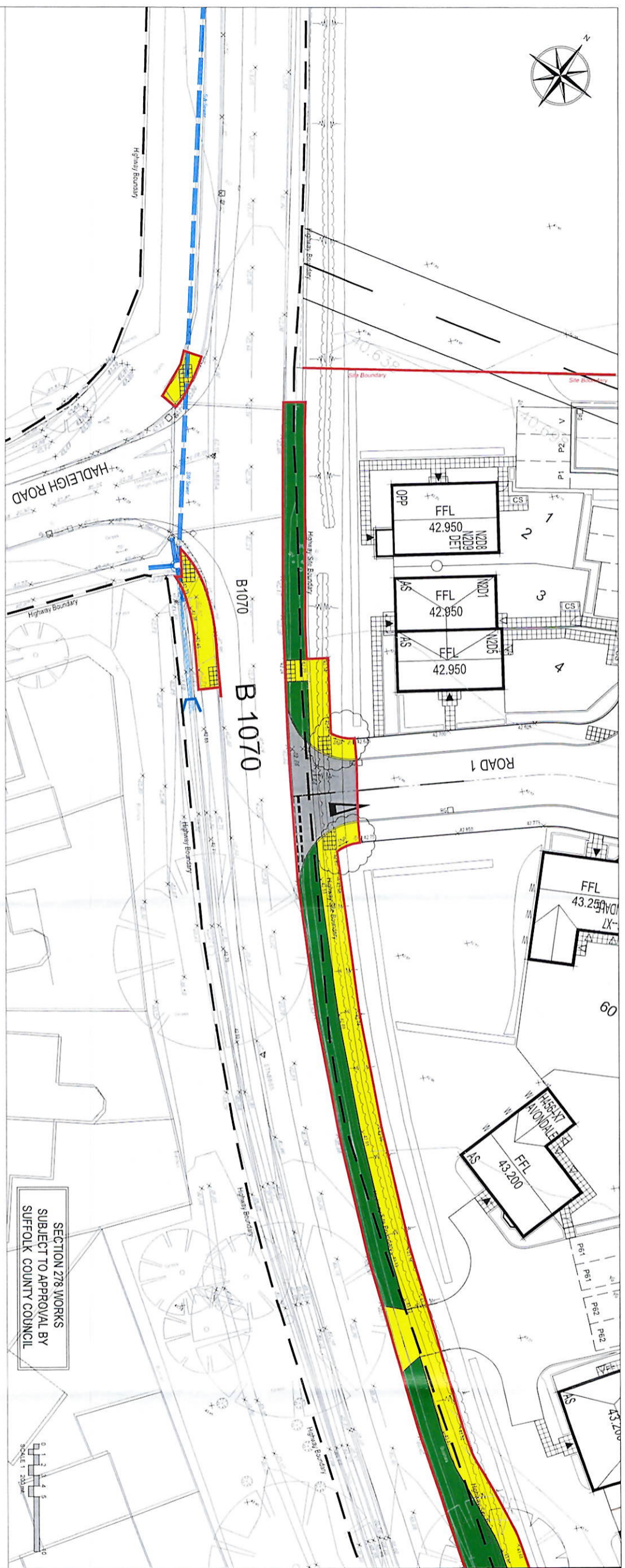

SECTION 278 WORKS  
SUBJECT TO APPROVAL BY  
SUFFOLK COUNTY COUNCIL

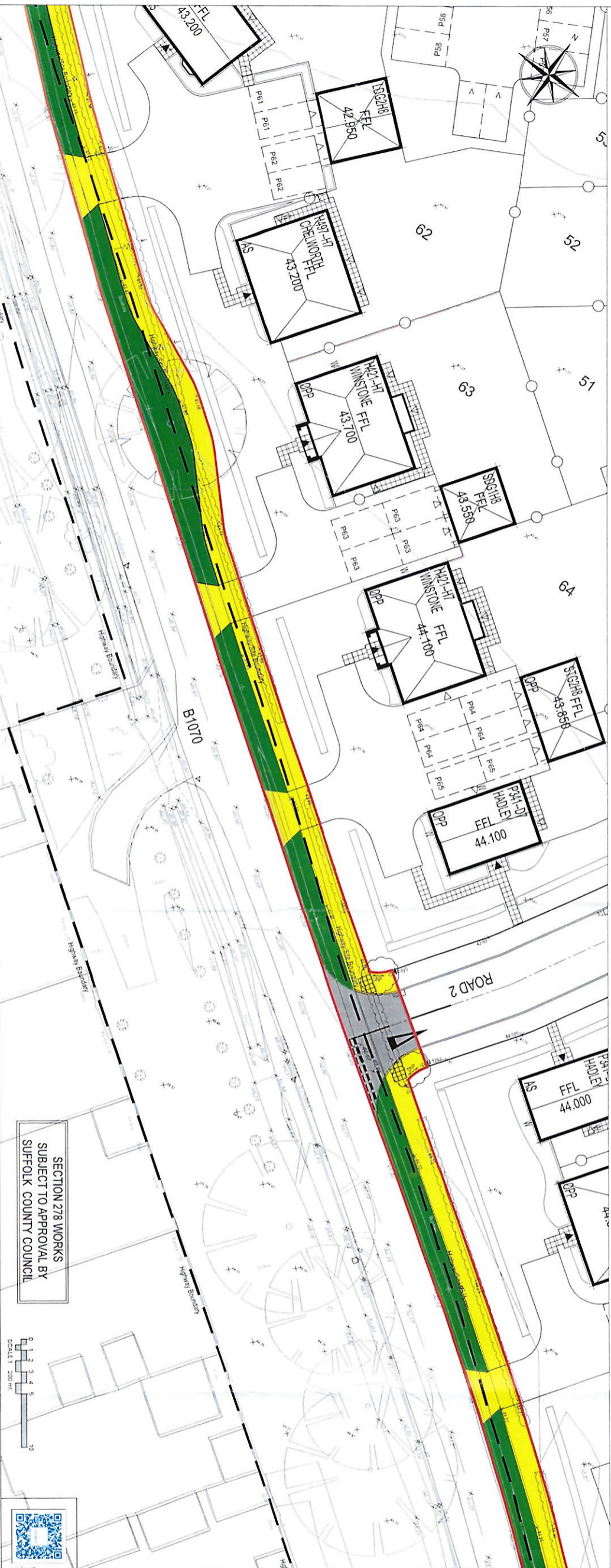

SECTION 278 WORKS  
SUBJECT TO APPROVAL BY  
SUFFOLK COUNTY COUNCIL

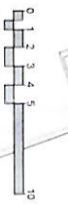

No Dimensions are to be scaled from this drawing.

1. All works carried out on the Public Highway are to be carried out in accordance with the Suffolk County Council (Suffolk) Road Works Regulations 2015.
2. The contractor is responsible for obtaining all necessary permits for works on the Public Highway and for the safe storage and use of all materials and equipment on the site.
3. The contractor shall ensure that the site is safe for the public and that all necessary precautions are taken to protect the public and the environment.
4. The contractor shall ensure that the site is safe for the public and that all necessary precautions are taken to protect the public and the environment.
5. The contractor shall ensure that the site is safe for the public and that all necessary precautions are taken to protect the public and the environment.
6. The contractor shall ensure that the site is safe for the public and that all necessary precautions are taken to protect the public and the environment.
7. The contractor shall ensure that the site is safe for the public and that all necessary precautions are taken to protect the public and the environment.
8. The contractor shall ensure that the site is safe for the public and that all necessary precautions are taken to protect the public and the environment.
9. The contractor shall ensure that the site is safe for the public and that all necessary precautions are taken to protect the public and the environment.
10. The contractor shall ensure that the site is safe for the public and that all necessary precautions are taken to protect the public and the environment.
11. The contractor shall ensure that the site is safe for the public and that all necessary precautions are taken to protect the public and the environment.
12. The contractor shall ensure that the site is safe for the public and that all necessary precautions are taken to protect the public and the environment.
13. The contractor shall ensure that the site is safe for the public and that all necessary precautions are taken to protect the public and the environment.
14. The contractor shall ensure that the site is safe for the public and that all necessary precautions are taken to protect the public and the environment.
15. The contractor shall ensure that the site is safe for the public and that all necessary precautions are taken to protect the public and the environment.

LEGEND

	Aggregate with Road Construction See eg. 18711-3B-GA-220
	Asphalt with Road Construction See eg. 18711-3B-GA-220
	Concrete with Road Construction See eg. 18711-3B-GA-220
	Gravel with Road Construction See eg. 18711-3B-GA-220
	Sand with Road Construction See eg. 18711-3B-GA-220
	Tarmac with Road Construction See eg. 18711-3B-GA-220
	Highway Boundary
	Site Boundary

**REVISIONS**

1	Initial Issue	20/02/22
2	Revised Issue	20/02/22
3	Revised Issue	20/02/22

**CLIENT**  
DAVID WILSON HOMES  
WHERE QUALITY LIVES

**PROJECT**  
MOORES LANE, EAST BERGHOLT  
SUFFOLK.

**DESIGNER**  
CIVIL ENGINEERING & INFRASTRUCTURE DESIGN  
Unit 12, Waters Hill Business Centre  
Waters Close, Colchester, Essex  
CO2 2DY  
01206 287081

**APPROVED BY**  
Brandon Schmidt

**DATE**  
1:200 @A1 05/22

**TENDER**  
H8771-3B-GA-220

**SCALE**  
1:200 @A1 05/22

**STATUS**  
MBS

**DATE**  
05/22

**BY**  
MBS

**CHECKED BY**  
MAW

**DATE**  
05/22

**BY**  
MAW

**SCALE**  
1:200 @A1 05/22

**TENDER**  
H8771-3B-GA-220

**STATUS**  
MBS

**DATE**  
05/22

**BY**  
MBS

**CHECKED BY**  
MAW

**DATE**  
05/22

**BY**  
MAW

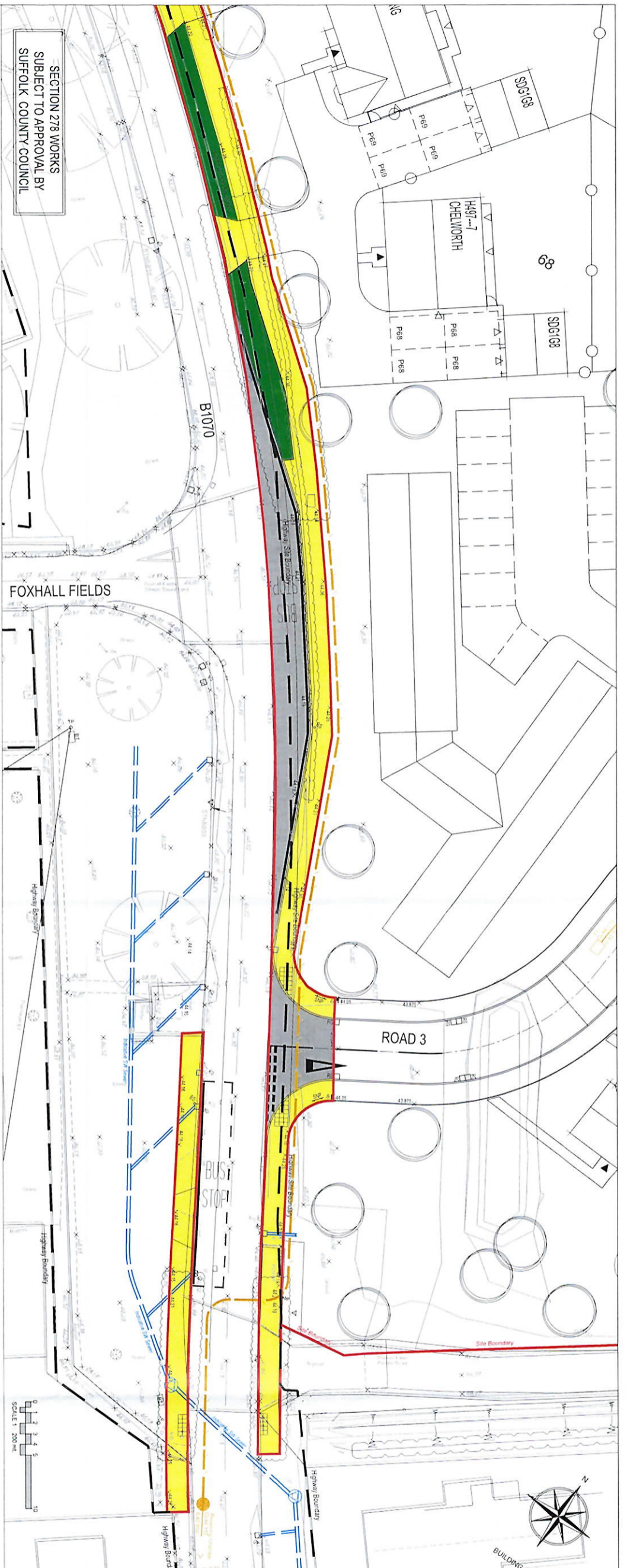

SECTION 278 WORKS  
SUBJECT TO APPROVAL BY  
SUFFOLK COUNTY COUNCIL

SCALE 1:200

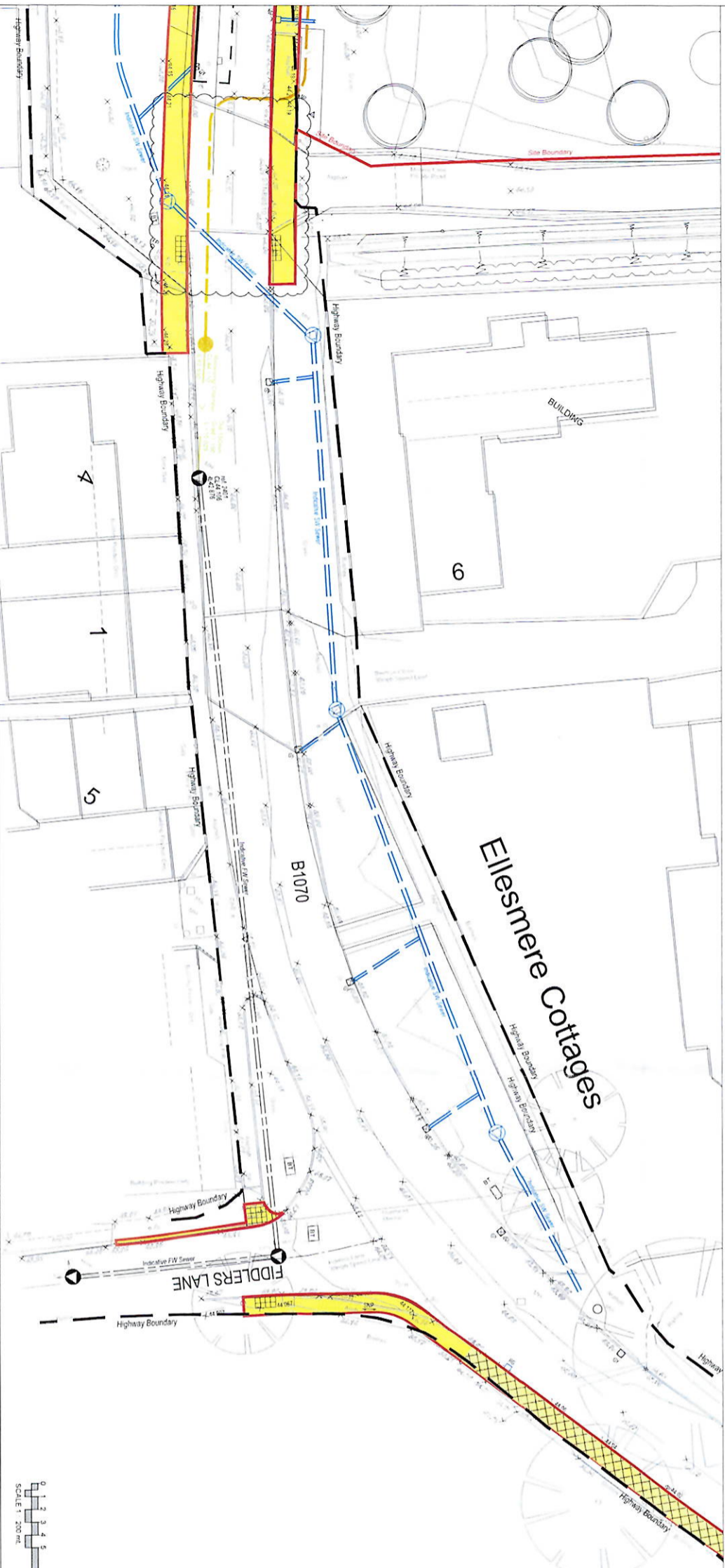

SECTION 278 WORKS  
SUBJECT TO APPROVAL BY  
SUFFOLK COUNTY COUNCIL

*Dan Griffin*  
**Dan Griffin**

SCALE 1:200

No Dimensions are to be scaled from this drawing.

- NOTES:
- All work shall be in accordance with the Highway Act 1980 and the Traffic Signs Regulations and General Directions 2002.
  - The proposed works shall be carried out in accordance with the Highway Act 1980 and the Traffic Signs Regulations and General Directions 2002.
  - The proposed works shall be carried out in accordance with the Highway Act 1980 and the Traffic Signs Regulations and General Directions 2002.
  - The proposed works shall be carried out in accordance with the Highway Act 1980 and the Traffic Signs Regulations and General Directions 2002.
  - The proposed works shall be carried out in accordance with the Highway Act 1980 and the Traffic Signs Regulations and General Directions 2002.
  - The proposed works shall be carried out in accordance with the Highway Act 1980 and the Traffic Signs Regulations and General Directions 2002.
  - The proposed works shall be carried out in accordance with the Highway Act 1980 and the Traffic Signs Regulations and General Directions 2002.
  - The proposed works shall be carried out in accordance with the Highway Act 1980 and the Traffic Signs Regulations and General Directions 2002.
  - The proposed works shall be carried out in accordance with the Highway Act 1980 and the Traffic Signs Regulations and General Directions 2002.
  - The proposed works shall be carried out in accordance with the Highway Act 1980 and the Traffic Signs Regulations and General Directions 2002.
  - The proposed works shall be carried out in accordance with the Highway Act 1980 and the Traffic Signs Regulations and General Directions 2002.
  - The proposed works shall be carried out in accordance with the Highway Act 1980 and the Traffic Signs Regulations and General Directions 2002.
  - The proposed works shall be carried out in accordance with the Highway Act 1980 and the Traffic Signs Regulations and General Directions 2002.
  - The proposed works shall be carried out in accordance with the Highway Act 1980 and the Traffic Signs Regulations and General Directions 2002.
  - The proposed works shall be carried out in accordance with the Highway Act 1980 and the Traffic Signs Regulations and General Directions 2002.

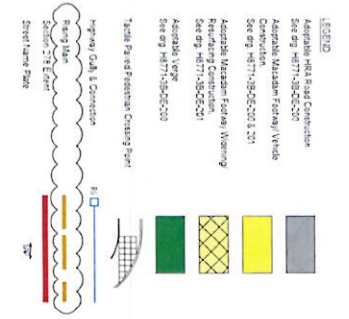

REVISIONS:

NO.	DESCRIPTION	DATE
1	Issue for approval	06/22
2	Issue for approval	06/22
3	Issue for approval	06/22
4	Issue for approval	06/22
5	Issue for approval	06/22
6	Issue for approval	06/22
7	Issue for approval	06/22
8	Issue for approval	06/22
9	Issue for approval	06/22
10	Issue for approval	06/22
11	Issue for approval	06/22
12	Issue for approval	06/22
13	Issue for approval	06/22
14	Issue for approval	06/22
15	Issue for approval	06/22
16	Issue for approval	06/22
17	Issue for approval	06/22
18	Issue for approval	06/22
19	Issue for approval	06/22
20	Issue for approval	06/22

**Brandon Schmidt**

**WITHERS**  
CIVIL ENGINEERING & INFRASTRUCTURE DESIGN  
Unit 12, Waters Hill Business Centre  
Waters Close, Colchester, Essex  
CO2 2DY  
01206 247081

**DAVID WILSON HOMES**  
WHERE QUALITY LIVES

**MOORES LANE, EAST BERGHOLT  
SUFFOLK.**

PROJECT: SECTION 278 WORKS  
CLIENT: SUFFOLK COUNTY COUNCIL  
DRAWING TITLE: AGREEMENT PLAN  
SHEET 2

SCALE: 1:200 @ A1  
DATE: 06/22  
STATUS: NBS  
TENDER: H8771-3B-GA-221  
DRAWING NO: 13

No Dimensions are to be scaled from this drawing

- NOTES**
1. All work shown on this Public Highway Agreement Plan is to be carried out in accordance with the Public Highway Act 1980 and the Statutory Instruments made thereunder.
  2. The agreement is intended to facilitate the maintenance of the highway.
  3. The Public Highway Agreement Plan shall be subject to the approval of the Highway Authority.
  4. The agreement shall be subject to the approval of the Highway Authority.
  5. The agreement shall be subject to the approval of the Highway Authority.
  6. The agreement shall be subject to the approval of the Highway Authority.
  7. The agreement shall be subject to the approval of the Highway Authority.
  8. The agreement shall be subject to the approval of the Highway Authority.
  9. The agreement shall be subject to the approval of the Highway Authority.
  10. The agreement shall be subject to the approval of the Highway Authority.
  11. The agreement shall be subject to the approval of the Highway Authority.
  12. The agreement shall be subject to the approval of the Highway Authority.
  13. The agreement shall be subject to the approval of the Highway Authority.
  14. The agreement shall be subject to the approval of the Highway Authority.
  15. The agreement shall be subject to the approval of the Highway Authority.
  16. The agreement shall be subject to the approval of the Highway Authority.

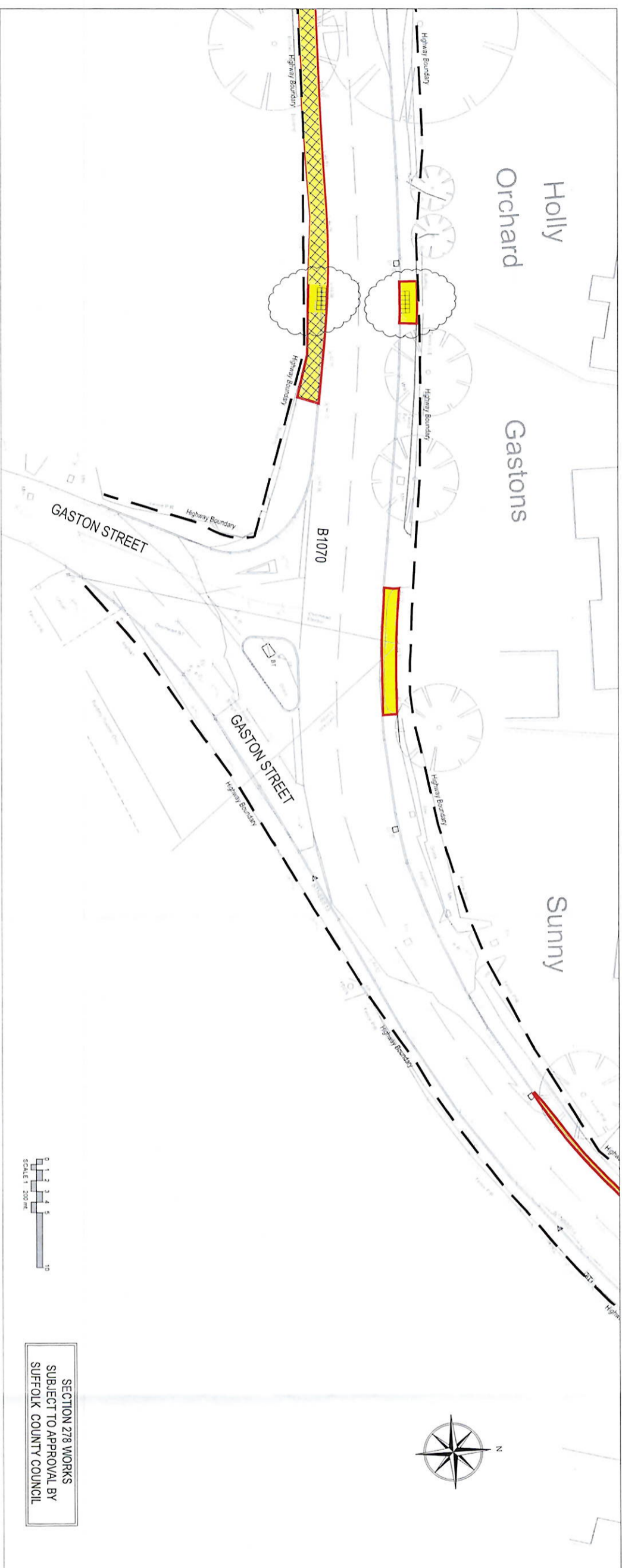

**SECTION 278 WORKS  
SUBJECT TO APPROVAL BY  
SUFFOLK COUNTY COUNCIL**

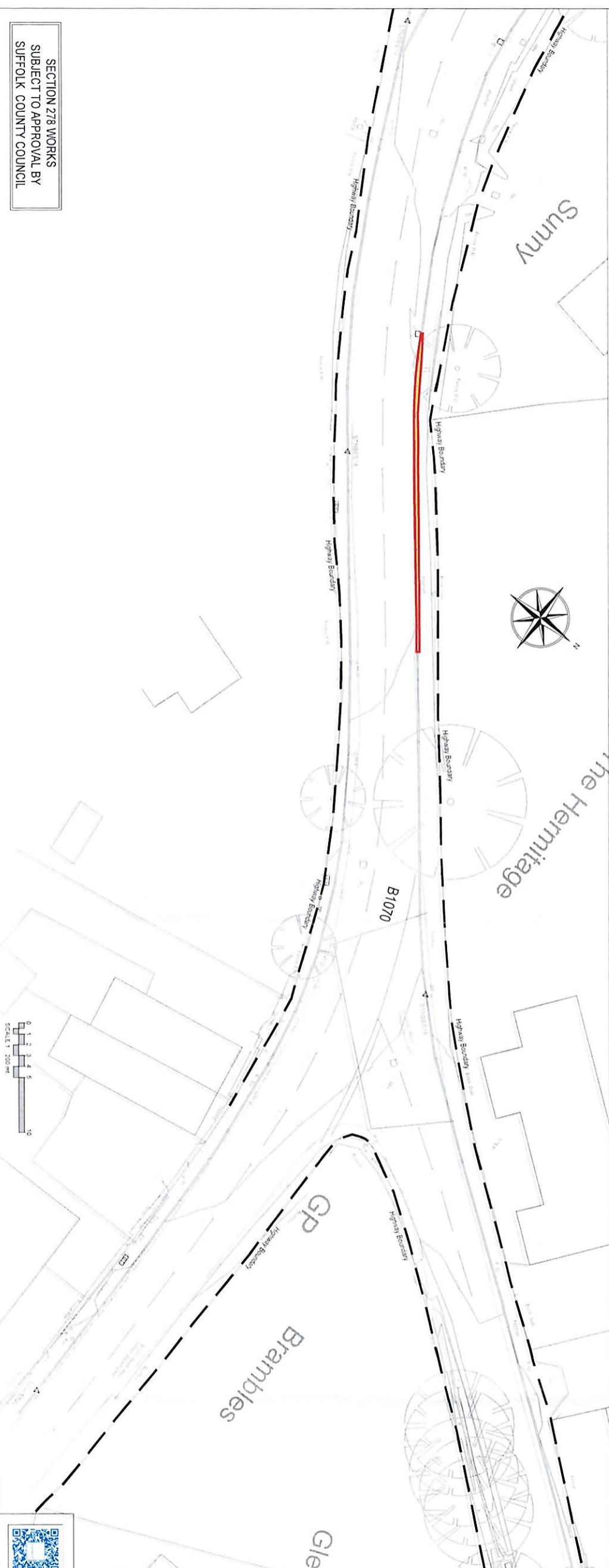

**SECTION 278 WORKS  
SUBJECT TO APPROVAL BY  
SUFFOLK COUNTY COUNCIL**

**Brandon Schmidt**

*Brandon Schmidt*

**Dan Griffin**

*Dan Griffin*

**W WITHERS**  
SHEFFEN ASSOCIATES

CIVIL ENGINEERING & INFRASTRUCTURE DESIGN

Unit 12, Waters Hall Business Centre  
Waters Hall, Colchester, Essex  
CO2 9EJ  
01206 240381

**DAVID WILSON HOMES**  
WHOLE QUALITY LIVES

**SECTION 278  
AGREEMENT PLAN**  
Sheet 3

DATE	DAT	BY	CHKD
1:200 @A1	0622	NBS	MAY
TENDER			
NO			
H0774-3B-GA-222			T2

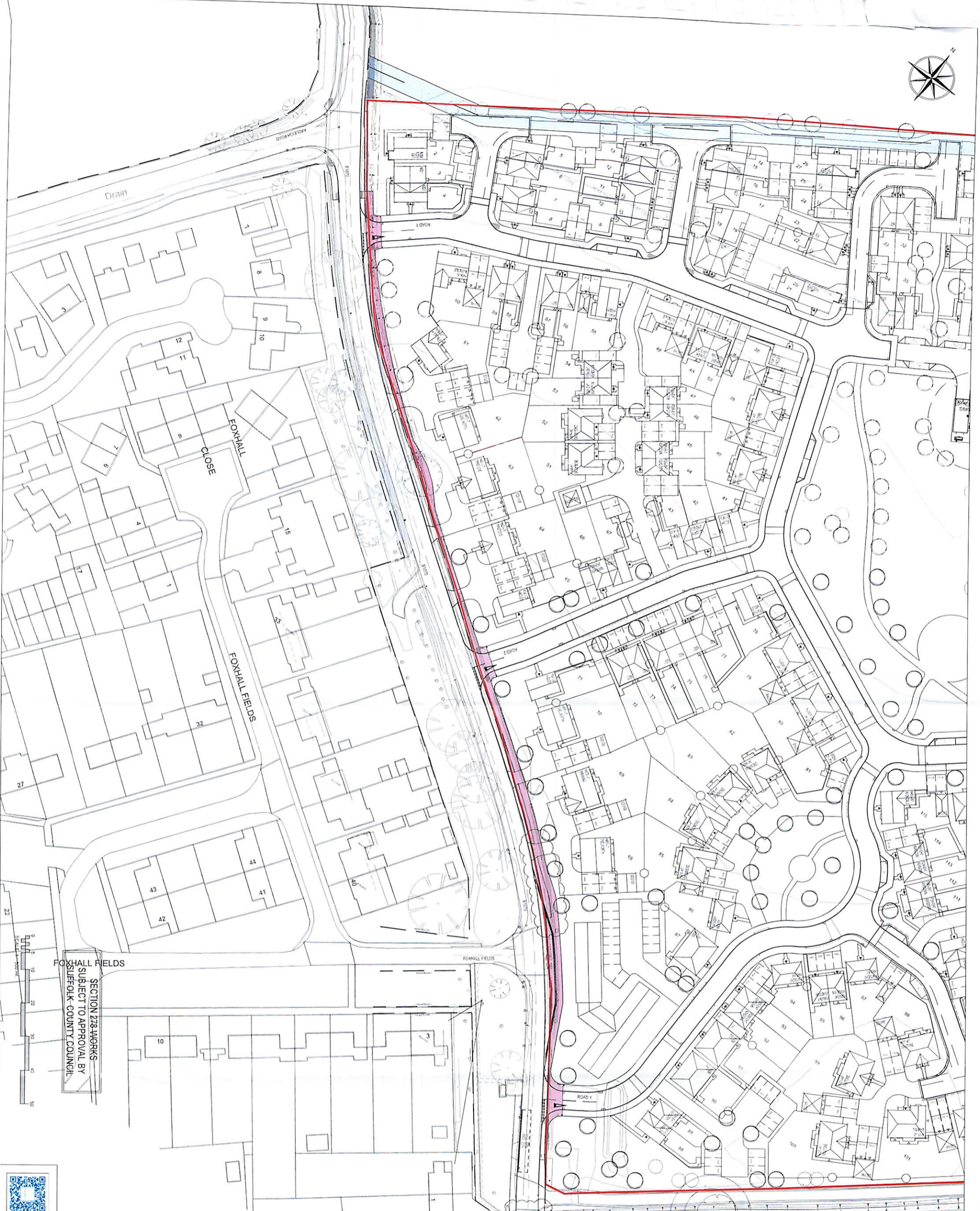

No Dimensions are to be scaled from this drawing.

- NOTES**
- All works are to be done in accordance with the current edition of the Highway Act 1996 and the current edition of the Highway Regulations 2002.
  - The contractor is responsible for obtaining all necessary permits for works in the Public Highway.
  - The contractor is to provide suitable and effective means of access to the highway at all times during the duration of the works.
  - All existing trees and other vegetation are to be protected and preserved where possible.
  - All existing trees and other vegetation are to be protected and preserved where possible.
  - Construction of access to be completed to the satisfaction of the Statutory CC Engineer and the Highway Authority.
  - The Statutory CC Engineer is to provide suitable and effective means of access to the highway at all times during the duration of the works.
  - All works are to be completed in accordance with the current edition of the Highway Act 1996 and the current edition of the Highway Regulations 2002.
  - The contractor is to provide suitable and effective means of access to the highway at all times during the duration of the works.
  - All works are to be completed in accordance with the current edition of the Highway Act 1996 and the current edition of the Highway Regulations 2002.

**LEGEND**

Land to be Deeded as Highway

Highway Boundary

Proposed Highway

*Brandon Schmidt*  
**Brandon Schmidt**

*Dan Griffin*  
**Dan Griffin**

**WITHERS**  
CIVIL ENGINEERING & INFRASTRUCTURE DESIGN  
Unit 12 Waterside Business Centre  
Waterloo Quay, Colchester, CO2 2JF  
01206 527081

**DAVID WILSON HOMES**  
WHERE QUALITY MEETS AFFORDABILITY

**SECTION 278 LAND ADOPTION**

**SECTION 278 - WORKS SUBJECT TO APPROVAL BY SUFFOLK COUNTY COUNCIL**

**MOORES LANE, EAST BERGHOLT SUFFOLK.**

PROJECT NO: H8771-3B-GA-223  
DRAWING NO: T2

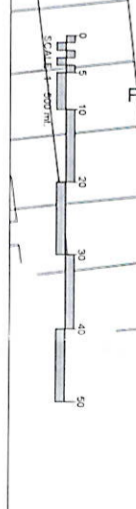

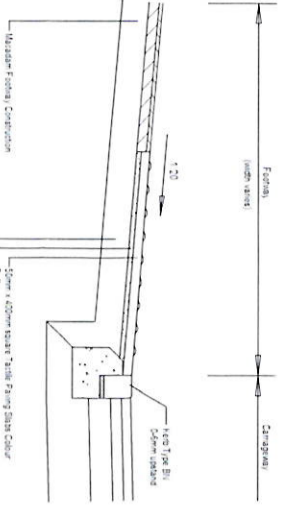

SECTION THROUGH TACTILE PAVED CROSSING  
Scale 1:20

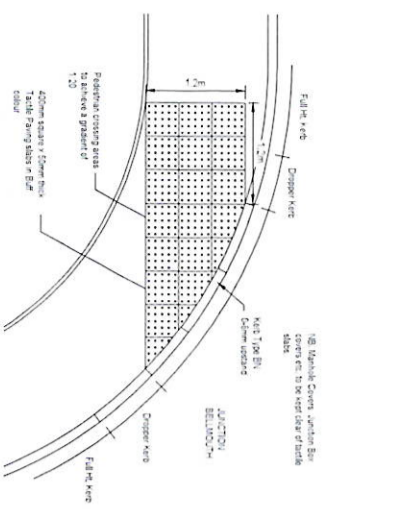

TACTILE PAVED PEDESTRIAN/RAMP CROSSINGS  
Scale 1:25

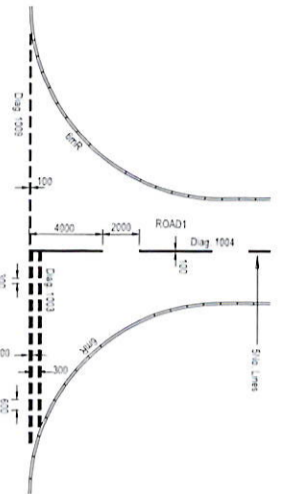

GIVE WAY MARKINGS SCHEMATIC  
Scale 1:20

Dist (m)	Size (mm)	Description
1000	600 x 200 (300 gap) 200 high	Give way
1004	4000 x 100 (2000 gap)	Highway marking
1008	600 x 150 (300 gap)	Edge of carriageway junction
1023	250 x 150 (50 gap)	Give way triangle

ROAD MARKINGS SCHEDULE

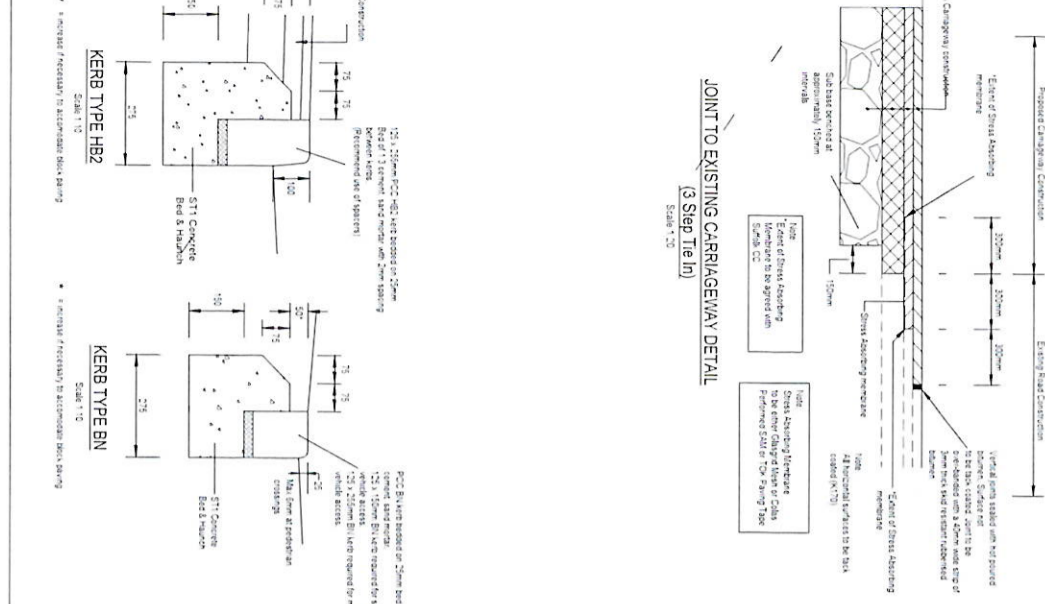
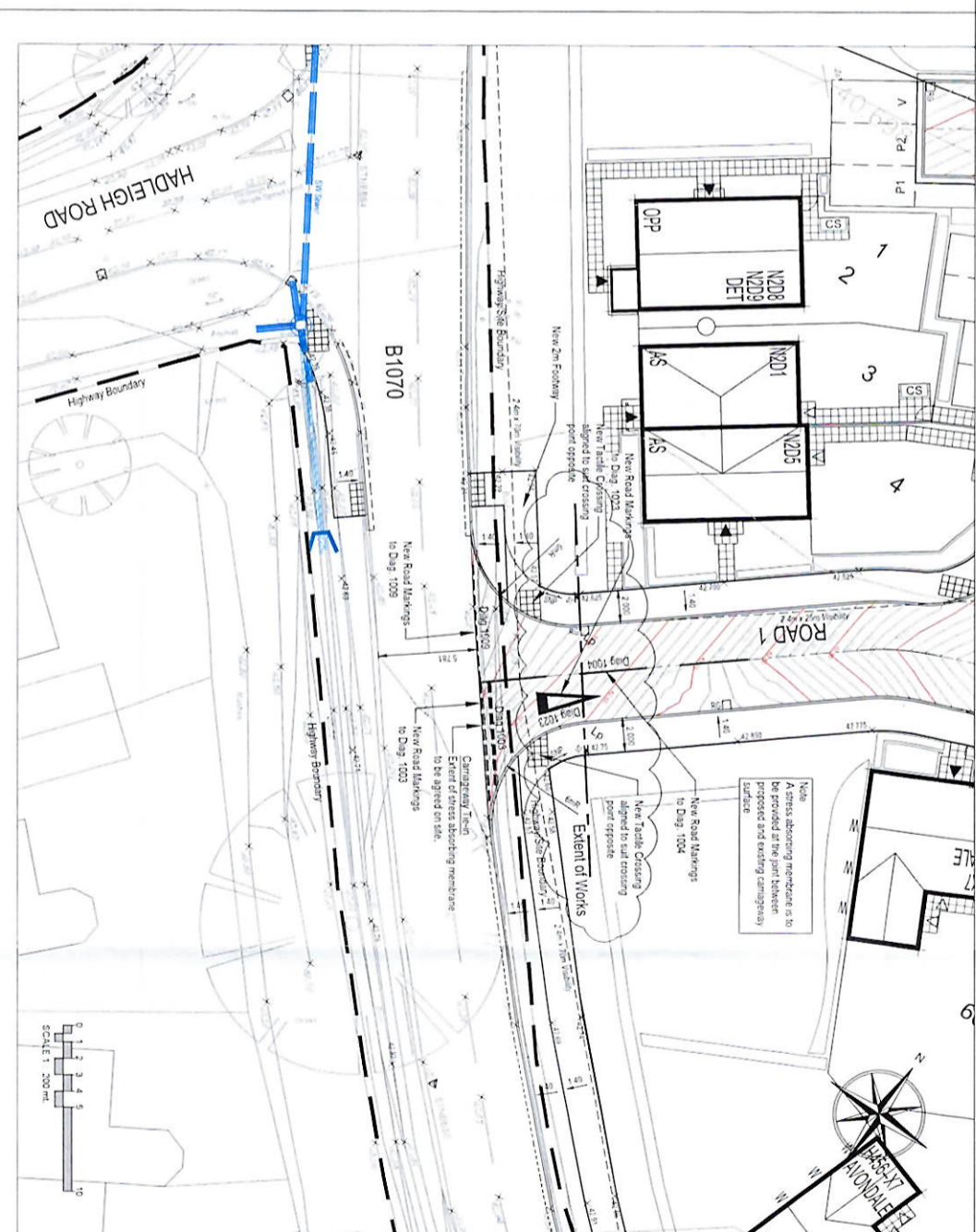

JOINT TO EXISTING CARRIAGEWAY DETAIL  
(3 Step Tie In)  
Scale 1:25

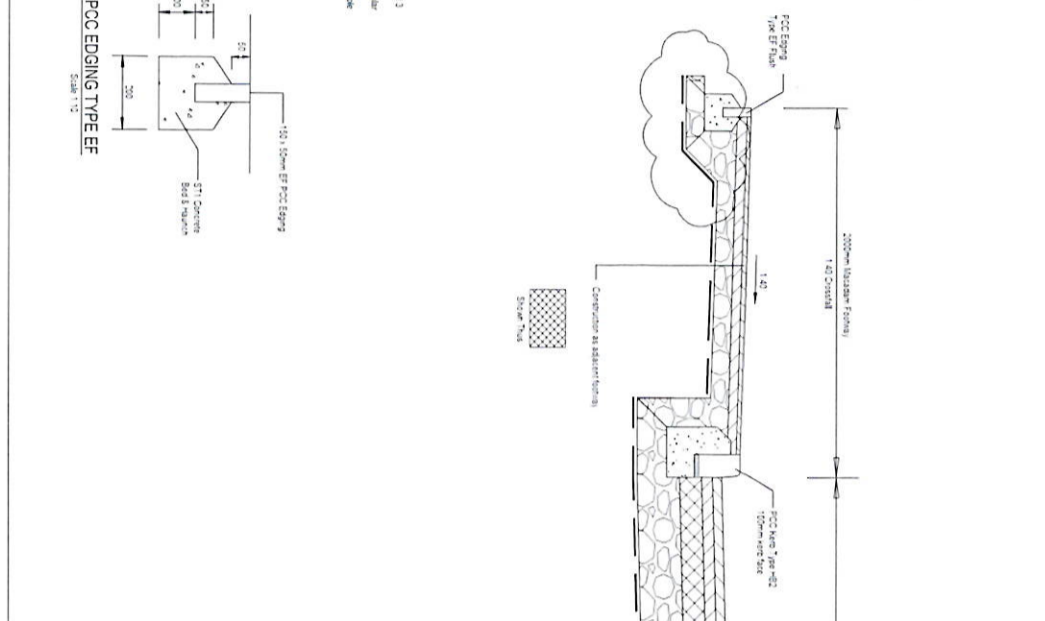

KERB TYPE HBZ  
Scale 1:25

KERB TYPE BN  
Scale 1:25

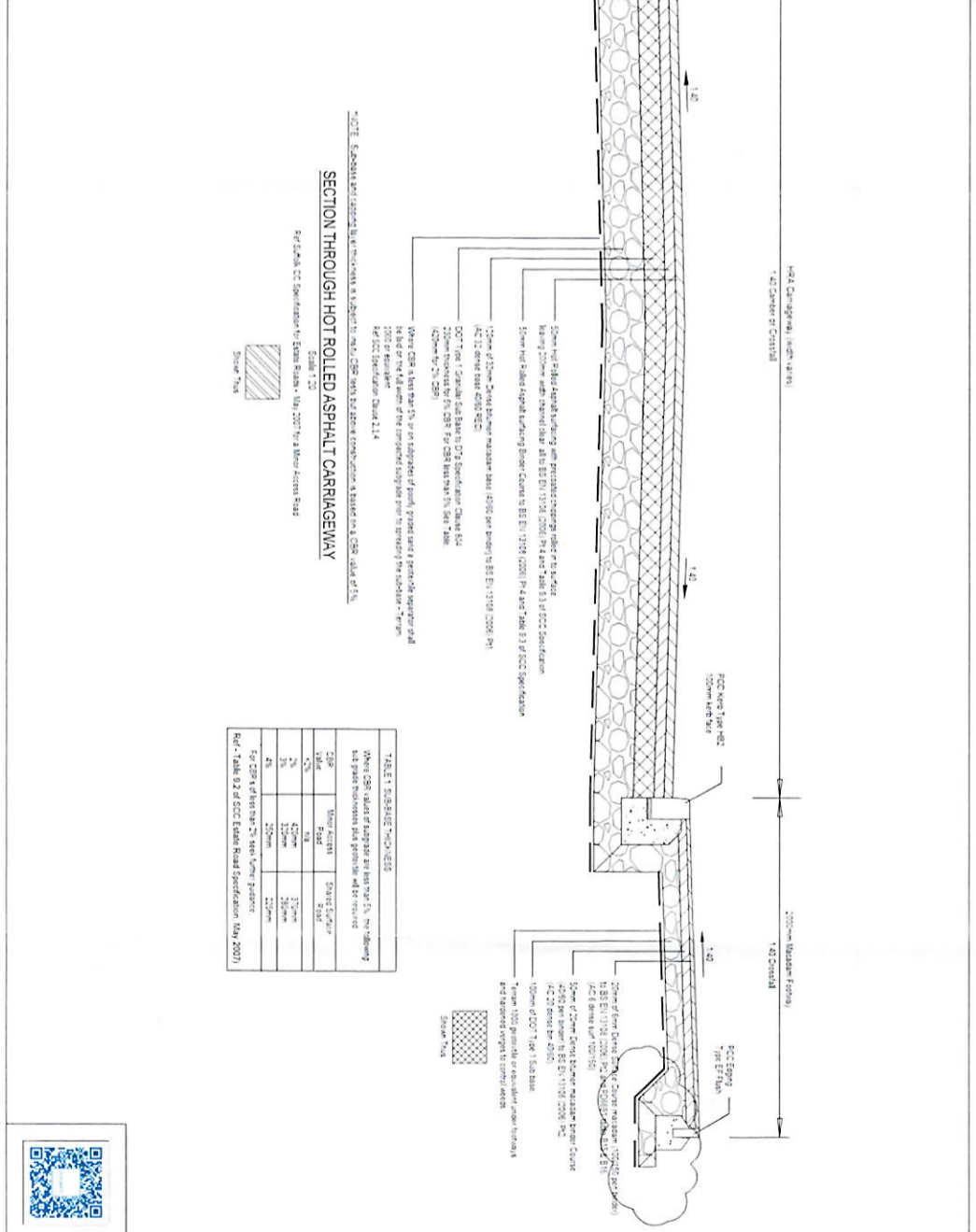

SECTION THROUGH HOT ROLLED ASPHALT CARRIAGEWAY  
Scale 1:20

Layer	Material	Thickness
1	Subgrade	As per ground conditions
2	Sub-base	100mm
3	Base	100mm
4	Hot Rolled Asphalt	100mm
5	Surface	100mm

No Dimensions are to be scaled from this drawing.

NOTES:  
1. All works shown on this drawing are to be carried out in accordance with the British Standard Specification for the materials of the highway works.  
2. The contractor is responsible for obtaining all necessary permits for works in the public highway.  
3. The contractor shall be responsible for the safety of the public highway. The contractor shall be responsible for the safety of the public highway. The contractor shall be responsible for the safety of the public highway.  
4. The contractor shall be responsible for the safety of the public highway. The contractor shall be responsible for the safety of the public highway. The contractor shall be responsible for the safety of the public highway.  
5. The contractor shall be responsible for the safety of the public highway. The contractor shall be responsible for the safety of the public highway. The contractor shall be responsible for the safety of the public highway.  
6. The contractor shall be responsible for the safety of the public highway. The contractor shall be responsible for the safety of the public highway. The contractor shall be responsible for the safety of the public highway.  
7. The contractor shall be responsible for the safety of the public highway. The contractor shall be responsible for the safety of the public highway. The contractor shall be responsible for the safety of the public highway.  
8. The contractor shall be responsible for the safety of the public highway. The contractor shall be responsible for the safety of the public highway. The contractor shall be responsible for the safety of the public highway.  
9. The contractor shall be responsible for the safety of the public highway. The contractor shall be responsible for the safety of the public highway. The contractor shall be responsible for the safety of the public highway.  
10. The contractor shall be responsible for the safety of the public highway. The contractor shall be responsible for the safety of the public highway. The contractor shall be responsible for the safety of the public highway.  
11. The contractor shall be responsible for the safety of the public highway. The contractor shall be responsible for the safety of the public highway. The contractor shall be responsible for the safety of the public highway.  
12. The contractor shall be responsible for the safety of the public highway. The contractor shall be responsible for the safety of the public highway. The contractor shall be responsible for the safety of the public highway.  
13. The contractor shall be responsible for the safety of the public highway. The contractor shall be responsible for the safety of the public highway. The contractor shall be responsible for the safety of the public highway.  
14. The contractor shall be responsible for the safety of the public highway. The contractor shall be responsible for the safety of the public highway. The contractor shall be responsible for the safety of the public highway.  
15. The contractor shall be responsible for the safety of the public highway. The contractor shall be responsible for the safety of the public highway. The contractor shall be responsible for the safety of the public highway.  
16. The contractor shall be responsible for the safety of the public highway. The contractor shall be responsible for the safety of the public highway. The contractor shall be responsible for the safety of the public highway.  
17. The contractor shall be responsible for the safety of the public highway. The contractor shall be responsible for the safety of the public highway. The contractor shall be responsible for the safety of the public highway.  
18. The contractor shall be responsible for the safety of the public highway. The contractor shall be responsible for the safety of the public highway. The contractor shall be responsible for the safety of the public highway.  
19. The contractor shall be responsible for the safety of the public highway. The contractor shall be responsible for the safety of the public highway. The contractor shall be responsible for the safety of the public highway.  
20. The contractor shall be responsible for the safety of the public highway. The contractor shall be responsible for the safety of the public highway. The contractor shall be responsible for the safety of the public highway.

Legend:  
Proposed Tactile Paving  
Proposed Finished Level  
Existing Gully Level  
Highway Boundary

Client: MOORES LANE, EAST BERGHOLT, SUFFOLK.

DAVID WILSON HOMES  
WHERE QUALITY LIVES

CIVIL ENGINEERING & INFRASTRUCTURE DESIGN  
Unit 12, Waters Hill Business Centre  
Waters Close, Colchester, Essex  
CO1 2DT  
01206 249050

WITHERS DESIGN ASSOCIATES

Dan Griffin  
Brandon Schmidt

TEMPORARY SITE ACCESS (ROAD 1)

SCALE: DATE: 1:200 @A1 07/22  
STATUS: NMS  
TENDER: nms  
CHNO: cb  
DRAWING NO: H8771-3B-GA-240  
REVISION: 12



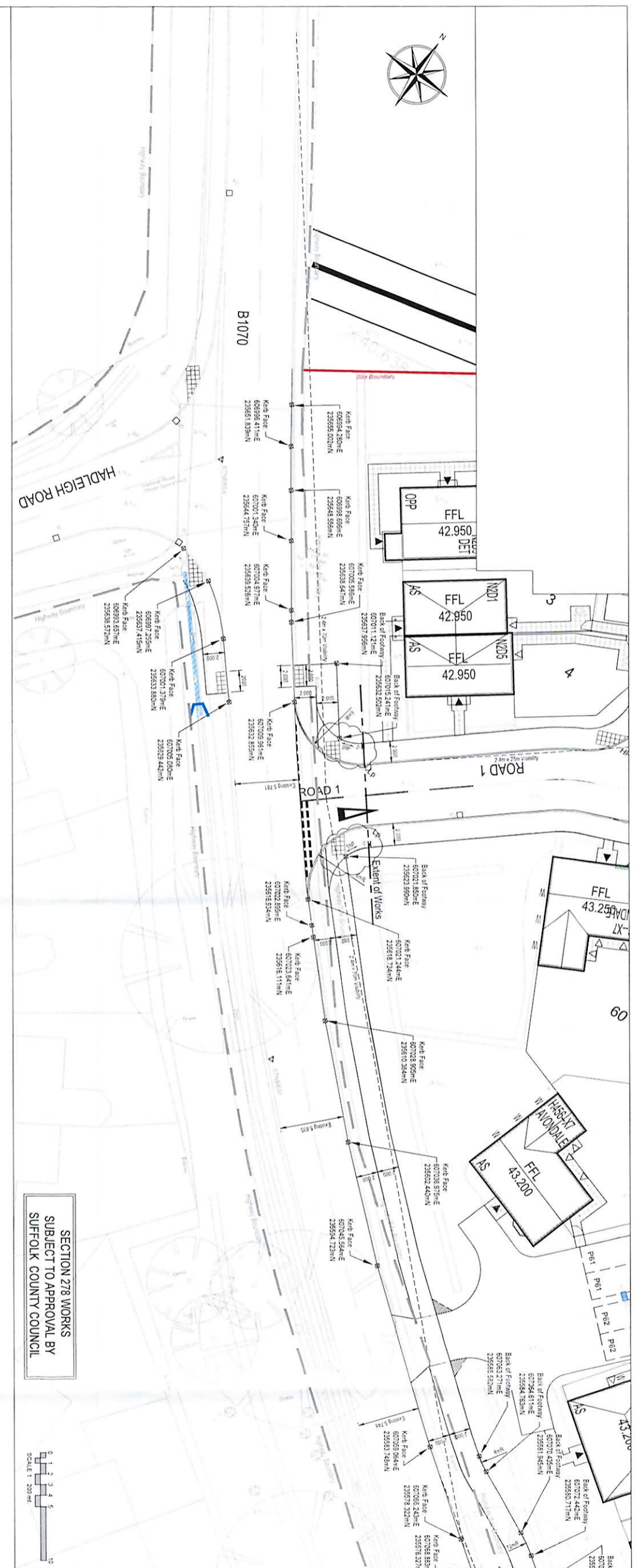

SECTION 278 WORKS  
SUBJECT TO APPROVAL BY  
SUFFOLK COUNTY COUNCIL

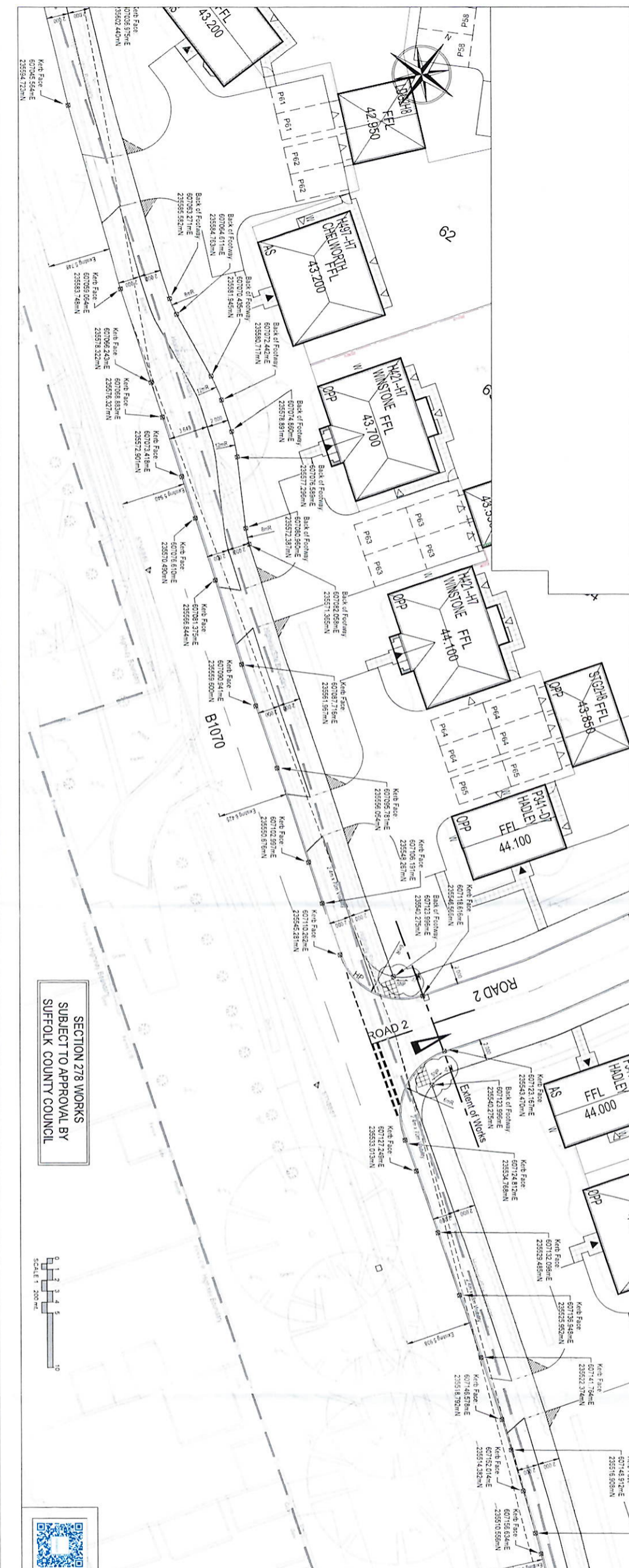
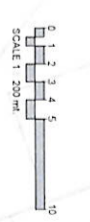

SECTION 278 WORKS  
SUBJECT TO APPROVAL BY  
SUFFOLK COUNTY COUNCIL

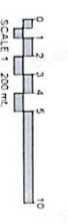

No Dimensions are to be scaled from this drawing.

1. The Contractor shall be responsible for obtaining all necessary permits for works in the public highway from the relevant authority.
2. The Contractor shall be responsible for obtaining all necessary permits for works in the private highway from the relevant authority.
3. The Contractor shall be responsible for obtaining all necessary permits for works in the private highway from the relevant authority.
4. The Contractor shall be responsible for obtaining all necessary permits for works in the private highway from the relevant authority.
5. The Contractor shall be responsible for obtaining all necessary permits for works in the private highway from the relevant authority.
6. The Contractor shall be responsible for obtaining all necessary permits for works in the private highway from the relevant authority.
7. The Contractor shall be responsible for obtaining all necessary permits for works in the private highway from the relevant authority.
8. The Contractor shall be responsible for obtaining all necessary permits for works in the private highway from the relevant authority.
9. The Contractor shall be responsible for obtaining all necessary permits for works in the private highway from the relevant authority.
10. The Contractor shall be responsible for obtaining all necessary permits for works in the private highway from the relevant authority.
11. The Contractor shall be responsible for obtaining all necessary permits for works in the private highway from the relevant authority.
12. The Contractor shall be responsible for obtaining all necessary permits for works in the private highway from the relevant authority.
13. The Contractor shall be responsible for obtaining all necessary permits for works in the private highway from the relevant authority.
14. The Contractor shall be responsible for obtaining all necessary permits for works in the private highway from the relevant authority.
15. The Contractor shall be responsible for obtaining all necessary permits for works in the private highway from the relevant authority.
16. The Contractor shall be responsible for obtaining all necessary permits for works in the private highway from the relevant authority.



REVISIONS  
1. Proposed Works  
2. Highway Boundary

**Dan Griffin**  
Brandon Gehrigt

**WITHERS**  
DESIGN ASSOCIATES  
CIVIL ENGINEERING & INFRASTRUCTURE DESIGN  
Unit 12, Welles Hall Business Centre  
Welles, Colchester, Essex  
CO2 0DY  
0206 240081

**DAVID WILSON HOMES**  
WHERE QUALITY LIVES

PROJECT  
MOORES LANE, EAST BERGHOLT  
SUFFOLK.

SCALE DATE  
1:200 @A1 07/22  
TENDER  
H8771-3B-GA-250

ALIGNMENT	GRADE	EASTING	NORTHING	LEVEL	RADIUS	BEARINGS	ANGLE	ARC LENGTH	TANG
JP3-1	0.000	607207.905	235447.634	-999.600					
CP3-1	10.000	607216.918	235452.918	43.928					
TP3-1a	13.669	607219.510	235454.856	43.991					

JUNCTION DETAILS ROAD 3 - EX RD CH LH Side		JUNCTION DETAILS ROAD 3 - EX RD CH RH Side	
Curve 1	Curve 2	Curve 1	Curve 2
Centre O1	Centre O2	Centre O1	Centre O2
607208.207	607217.745	607217.745	607217.745
607203.246	607212.703	607212.703	607212.703
607211.438	607214.575	607214.575	607214.575
235454.165	235443.452	235443.452	235443.452
235454.880	235440.200	235440.200	235440.200
235452.072	235448.548	235448.548	235448.548
43.921	44.103	44.103	44.916
6.000	6.000	6.000	6.000

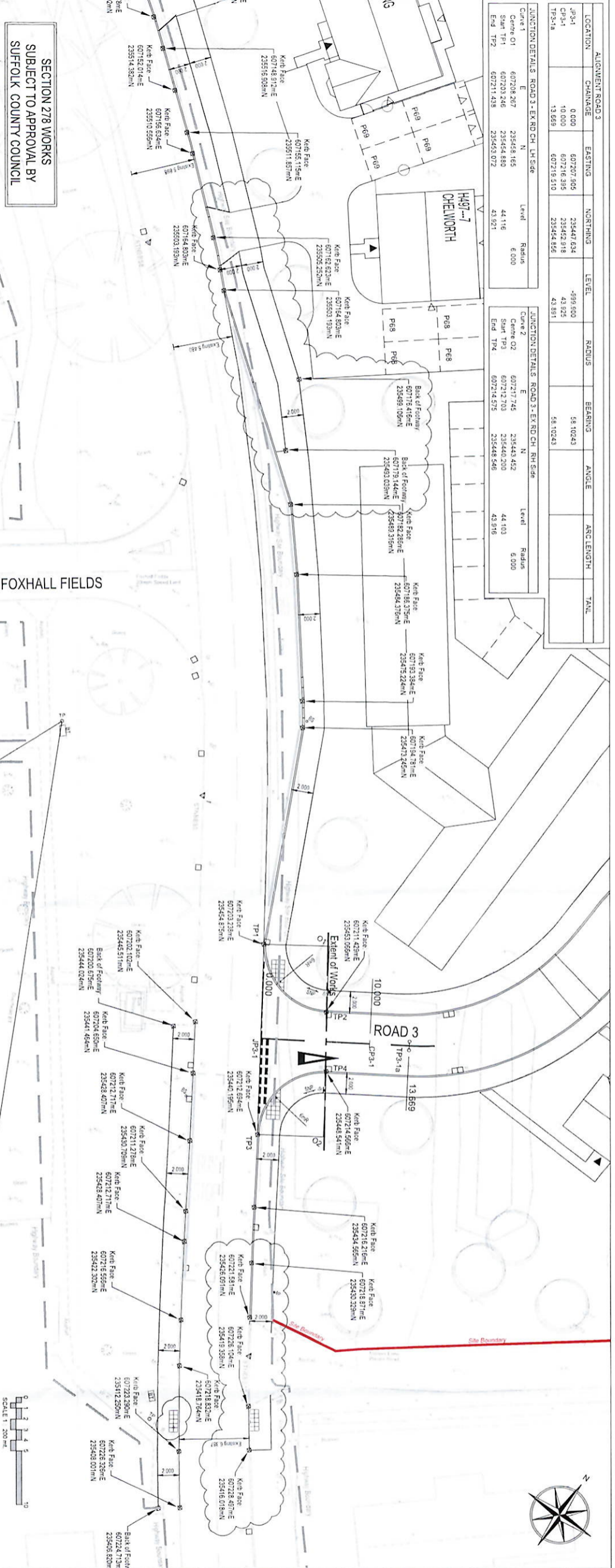

No Dimensions are to be scaled from this drawing.

NOTES:  
 1. All work shall be done in accordance with the current edition of the Highway Code and the Highway Regulations.  
 2. The contractor is responsible for obtaining all necessary permits for work in the public highway.  
 3. The contractor shall be responsible for the safety of the public highway during the course of the works.  
 4. The contractor shall be responsible for the safety of the public highway during the course of the works.  
 5. The contractor shall be responsible for the safety of the public highway during the course of the works.  
 6. The contractor shall be responsible for the safety of the public highway during the course of the works.  
 7. The contractor shall be responsible for the safety of the public highway during the course of the works.  
 8. The contractor shall be responsible for the safety of the public highway during the course of the works.  
 9. The contractor shall be responsible for the safety of the public highway during the course of the works.  
 10. The contractor shall be responsible for the safety of the public highway during the course of the works.  
 11. The contractor shall be responsible for the safety of the public highway during the course of the works.  
 12. The contractor shall be responsible for the safety of the public highway during the course of the works.  
 13. The contractor shall be responsible for the safety of the public highway during the course of the works.  
 14. The contractor shall be responsible for the safety of the public highway during the course of the works.  
 15. The contractor shall be responsible for the safety of the public highway during the course of the works.  
 16. The contractor shall be responsible for the safety of the public highway during the course of the works.

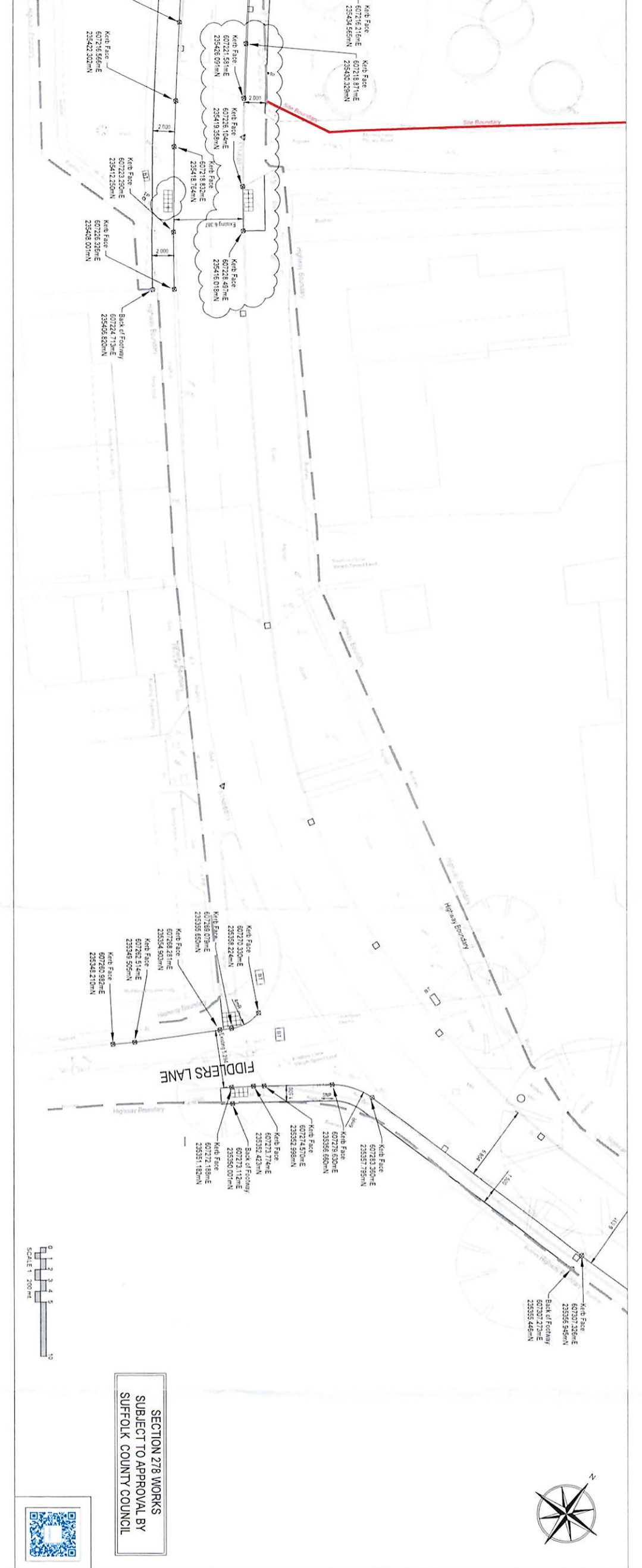

**SECTION 278 WORKS**  
 SUBJECT TO APPROVAL BY  
 SUFFOLK COUNTY COUNCIL

**SECTION 278**  
 SETTING OUT  
 Sheet 2

DATE: 07/22  
 DRAWN: @A1  
 TENDER: H871-3B-GA-251

SCALE: 1:200

**DAVID WILSON HOMES**  
 WHEEL QUALITY HAVES

**WITHERS**  
 CIVIL ENGINEERING & INFRASTRUCTURE DESIGN  
 Unit 12, Walker Hall Business Centre  
 Walker College, Colchester, Essex  
 CO2 2DY  
 01206 297081

**Brandon Schmidt**

**Dan Griffin**

**REVISION**

NO.	DESCRIPTION	DATE
1	Issue for tender	11/01/22
2	Issue for construction	11/01/22
3	Issue for construction	11/01/22
4	Issue for construction	11/01/22
5	Issue for construction	11/01/22
6	Issue for construction	11/01/22
7	Issue for construction	11/01/22
8	Issue for construction	11/01/22
9	Issue for construction	11/01/22
10	Issue for construction	11/01/22
11	Issue for construction	11/01/22
12	Issue for construction	11/01/22
13	Issue for construction	11/01/22
14	Issue for construction	11/01/22
15	Issue for construction	11/01/22
16	Issue for construction	11/01/22
17	Issue for construction	11/01/22
18	Issue for construction	11/01/22
19	Issue for construction	11/01/22
20	Issue for construction	11/01/22

SECTION 278 WORKS  
SUBJECT TO APPROVAL BY  
SUFFOLK COUNTY COUNCIL



SCALE	DATE	BY	CHKD
1:200 @A1	07/22	MAS	CB
TENDER			
DOC NO			
H8771-3B-GA-252			T1

DRAWING TITLE  
**SECTION 278  
SETTING OUT**  
Sheet 3



PROJECT  
**MOORES LANE, EAST BERGHOLT  
SUFFOLK**

CLIENT  
**DAVID WILSON HOMES**  
WHERE QUALITY LIVES

CIVIL ENGINEERING & INFRASTRUCTURE DESIGN  
**WITHERS**  
DESIGN ASSOCIATES  
Unit 12, Waters Hill Business Centre  
Waters Hill, Colchester, Essex  
CO3 2DY  
0206 2407581

**Brandon Schmidt**

*Brandon Schmidt*

**Dan Griffin**

*Dan Griffin*

REVISIONS

1	Issue for tender	15/07/22	450
2	Final design	15/07/22	510

**Legend**

Proposed Works

Hydrology Boundary

- NOTES**
- All works shown on this public highway are to be carried out in accordance with the Highway Code. Council identification to the satisfaction of the Highway Engineer is the responsibility of the contractor.
  - The contractor is responsible for obtaining all necessary permits for works on the public highway.
  - The speed limit for the road is 30 mph. The contractor must ensure that the road is closed to traffic for the duration of the works. The contractor must ensure that the road is closed to traffic for the duration of the works. The contractor must ensure that the road is closed to traffic for the duration of the works.
  - The contractor must ensure that the road is closed to traffic for the duration of the works. The contractor must ensure that the road is closed to traffic for the duration of the works. The contractor must ensure that the road is closed to traffic for the duration of the works.
  - The contractor must ensure that the road is closed to traffic for the duration of the works. The contractor must ensure that the road is closed to traffic for the duration of the works. The contractor must ensure that the road is closed to traffic for the duration of the works.
  - The contractor must ensure that the road is closed to traffic for the duration of the works. The contractor must ensure that the road is closed to traffic for the duration of the works. The contractor must ensure that the road is closed to traffic for the duration of the works.
  - The contractor must ensure that the road is closed to traffic for the duration of the works. The contractor must ensure that the road is closed to traffic for the duration of the works. The contractor must ensure that the road is closed to traffic for the duration of the works.
  - The contractor must ensure that the road is closed to traffic for the duration of the works. The contractor must ensure that the road is closed to traffic for the duration of the works. The contractor must ensure that the road is closed to traffic for the duration of the works.
  - The contractor must ensure that the road is closed to traffic for the duration of the works. The contractor must ensure that the road is closed to traffic for the duration of the works. The contractor must ensure that the road is closed to traffic for the duration of the works.
  - The contractor must ensure that the road is closed to traffic for the duration of the works. The contractor must ensure that the road is closed to traffic for the duration of the works. The contractor must ensure that the road is closed to traffic for the duration of the works.
  - The contractor must ensure that the road is closed to traffic for the duration of the works. The contractor must ensure that the road is closed to traffic for the duration of the works. The contractor must ensure that the road is closed to traffic for the duration of the works.
  - The contractor must ensure that the road is closed to traffic for the duration of the works. The contractor must ensure that the road is closed to traffic for the duration of the works. The contractor must ensure that the road is closed to traffic for the duration of the works.
  - The contractor must ensure that the road is closed to traffic for the duration of the works. The contractor must ensure that the road is closed to traffic for the duration of the works. The contractor must ensure that the road is closed to traffic for the duration of the works.
  - The contractor must ensure that the road is closed to traffic for the duration of the works. The contractor must ensure that the road is closed to traffic for the duration of the works. The contractor must ensure that the road is closed to traffic for the duration of the works.
  - The contractor must ensure that the road is closed to traffic for the duration of the works. The contractor must ensure that the road is closed to traffic for the duration of the works. The contractor must ensure that the road is closed to traffic for the duration of the works.

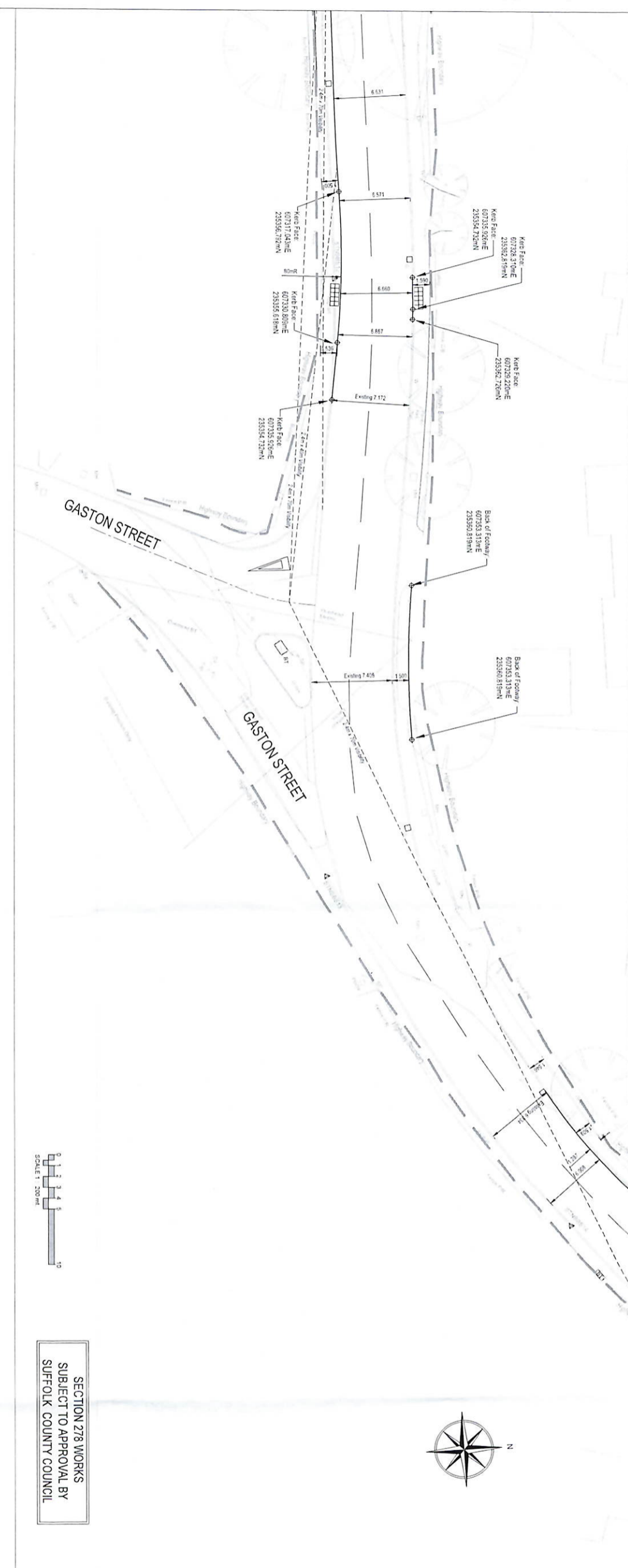
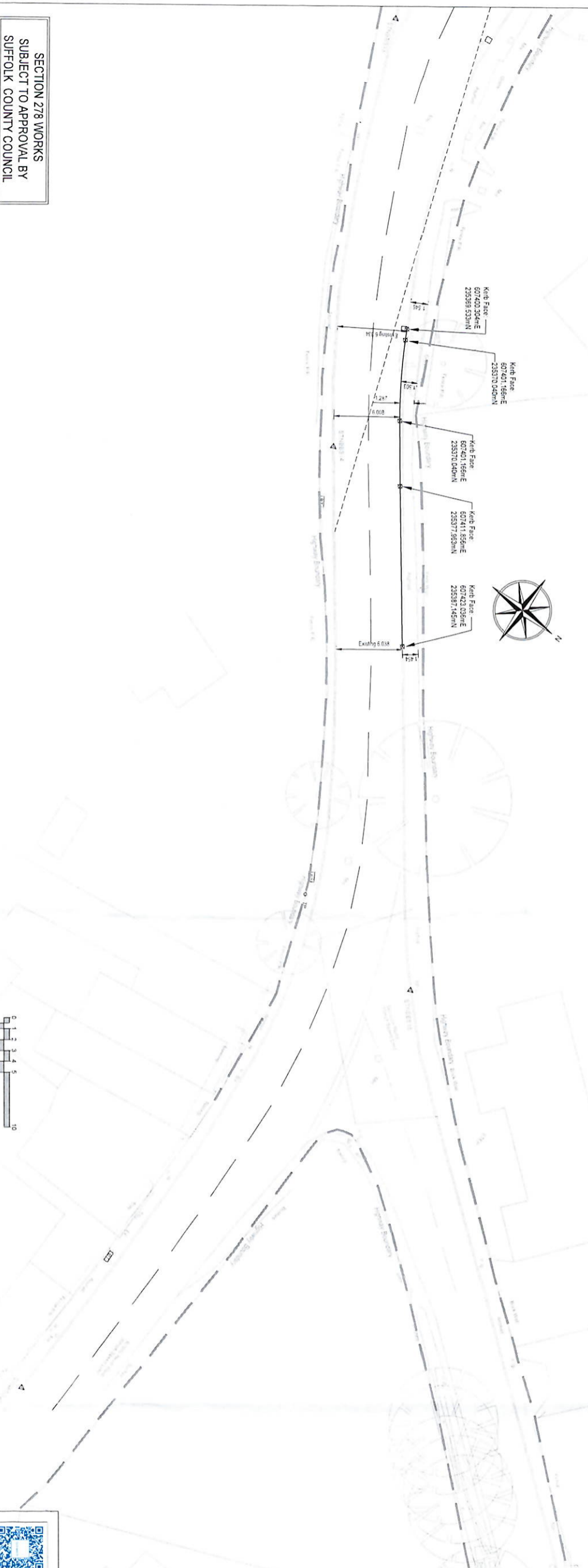

17.079	DATUM 42.000	
EXISTING GROUND	42.640	-2.351
OFFSET	42.647	-2.100
	42.627	-1.174
	42.437	-0.686
	42.187	-0.380
	42.193	-0.155
	42.195	0.000
	42.197	0.238
	42.634	0.691
	42.165	1.435
	42.252	2.641
	42.641	2.988



15	DATUM 42.000	
EXISTING GROUND	42.621	-2.413
OFFSET	42.621	-2.403
	42.584	-1.138
	42.457	-0.785
	42.111	-0.361
	42.119	-0.091
	42.120	0.000
	42.122	0.214
	42.225	0.840
	42.103	1.425
	42.809	2.227
	42.611	2.846

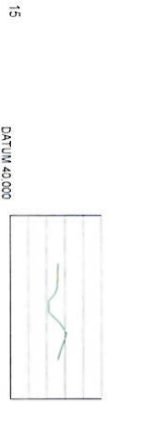

10	DATUM 42.000	
EXISTING GROUND	42.528	-2.546
OFFSET	42.518	-1.160
	42.515	-1.052
	42.504	-1.021
	41.928	-0.316
	41.938	0.000
	41.942	0.133
	41.942	0.158
	42.290	0.851
	42.581	1.211
	42.576	2.157
	42.515	2.357



05	DATUM 42.000	
EXISTING GROUND	42.420	-2.178
OFFSET	42.404	-1.317
	41.757	-0.670
	41.581	-0.452
	41.686	-0.058
	41.688	0.000
	41.690	0.078
	42.290	0.851
	42.581	1.211
	42.576	2.157
	42.515	2.357

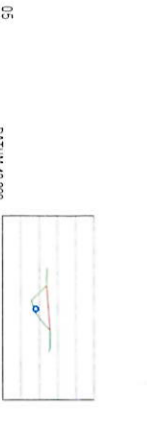

00	DATUM 42.000	
EXISTING GROUND	42.200	-1.160
OFFSET	42.280	0.000
	42.390	3.000



Existing ditch/Proposed Culvert Cross Sections	
Scale 1:200	

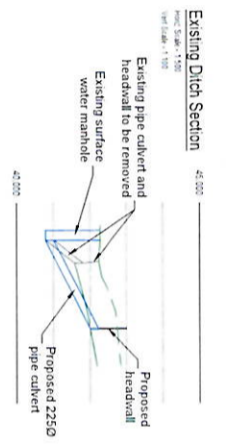

Change	0.000	5.000	10.000	15.000	17.079
EXISTING GROUND LEVEL	42.780	44.070	43.938	43.120	42.641
EXISTING PROPOSED LEVEL	42.780	44.070	43.938	43.120	42.641
PROPOSED LEVEL	42.780	44.070	43.938	43.120	42.641

Existing Ditch Long Section  
Scale 1:500

ROAD 1 SECTION  
Horiz Scale 1:500  
Vert Scale 1:100

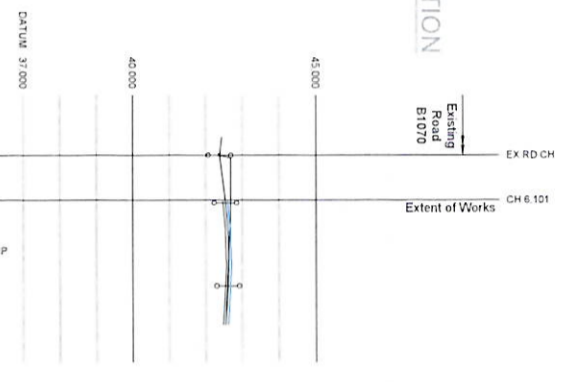

Station	Offset	Height	Grade
42.597	42.487	5.941	2.500%
42.605	42.540	6.454	1.250%
42.677	42.564	13.964	1.250%
42.702	42.514	17.703	1.250%
42.651	42.514	20.000	1.250%
42.614	42.477	22.988	1.250%

ROAD 2 SECTION  
Horiz Scale 1:500  
Vert Scale 1:100

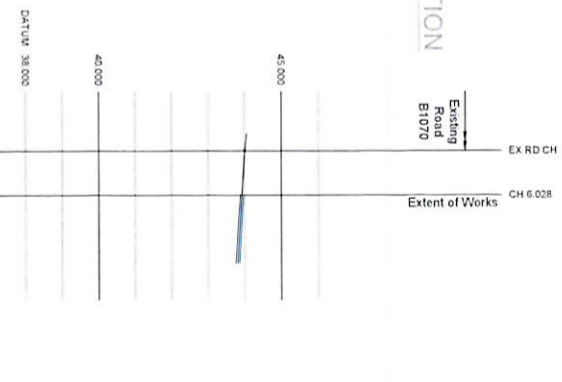

Station	Offset	Height	Grade
43.973	43.882	5.943	1.250%
43.928	43.882	6.133	1.250%
43.870	43.761	15.343	1.250%
43.866	43.756		1.250%

ROAD 3 SECTION  
Horiz Scale 1:500  
Vert Scale 1:100

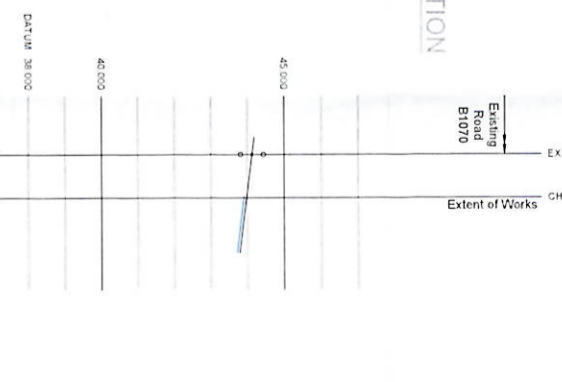

Station	Offset	Height	Grade
43.905	43.911	5.872	2.500%
43.808	43.808	6.145	1.250%
43.717	43.717	13.660	1.250%

SECTION 278 WORKS  
SUBJECT TO APPROVAL BY  
SUFFOLK COUNTY COUNCIL

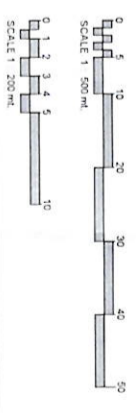

- No Dimensions are to be scaled from this drawing.
1. All work shall be carried out in accordance with the relevant British Standards and specifications for the materials and workmanship.
  2. The Contractor shall be responsible for obtaining all necessary permits for work in the Public Highway.
  3. The Contractor shall be responsible for obtaining all necessary permits for work in the Public Highway.
  4. All materials shall be stored in a secure and safe manner.
  5. All materials shall be stored in a secure and safe manner.
  6. All materials shall be stored in a secure and safe manner.
  7. All materials shall be stored in a secure and safe manner.
  8. All materials shall be stored in a secure and safe manner.
  9. All materials shall be stored in a secure and safe manner.
  10. All materials shall be stored in a secure and safe manner.
  11. All materials shall be stored in a secure and safe manner.
  12. All materials shall be stored in a secure and safe manner.
  13. All materials shall be stored in a secure and safe manner.
  14. All materials shall be stored in a secure and safe manner.
  15. All materials shall be stored in a secure and safe manner.
  16. All materials shall be stored in a secure and safe manner.

Brandon Schmidt  
*Brandon Schmidt*

nan Griffin  
*nan Griffin*

**W WITHERS**  
DESIGN ASSOCIATES  
CIVIL ENGINEERING & INFRASTRUCTURE DESIGN  
Unit 12, Vickers Hill Business Centre  
Waterside, Colchester, Essex, CO2 2DP  
01206 247081

DAVID WILSON HOMES  
WHERE QUALITY LIVES

SECTION 278 ROAD LONG  
SECTIONS AND EXISTING DITCH  
CROSS SECTIONS

SCALE	DWT	NHT	CND
1:200 @A1	07/22	cab	man
STATUS			
TENDER			
DRAWNO			KIBRON
H8771-3B-SE-200			T1